

**-Aken Tools Europa-
WTS Solutions GmbH
Lademannbogen 10, 3. OG
D-22339 Hamburg
Tel: +49 40 53930277
Fax: +49 40 53930279
Email: info@aken-tools.de
Webeseite: www.aken-tools.de**

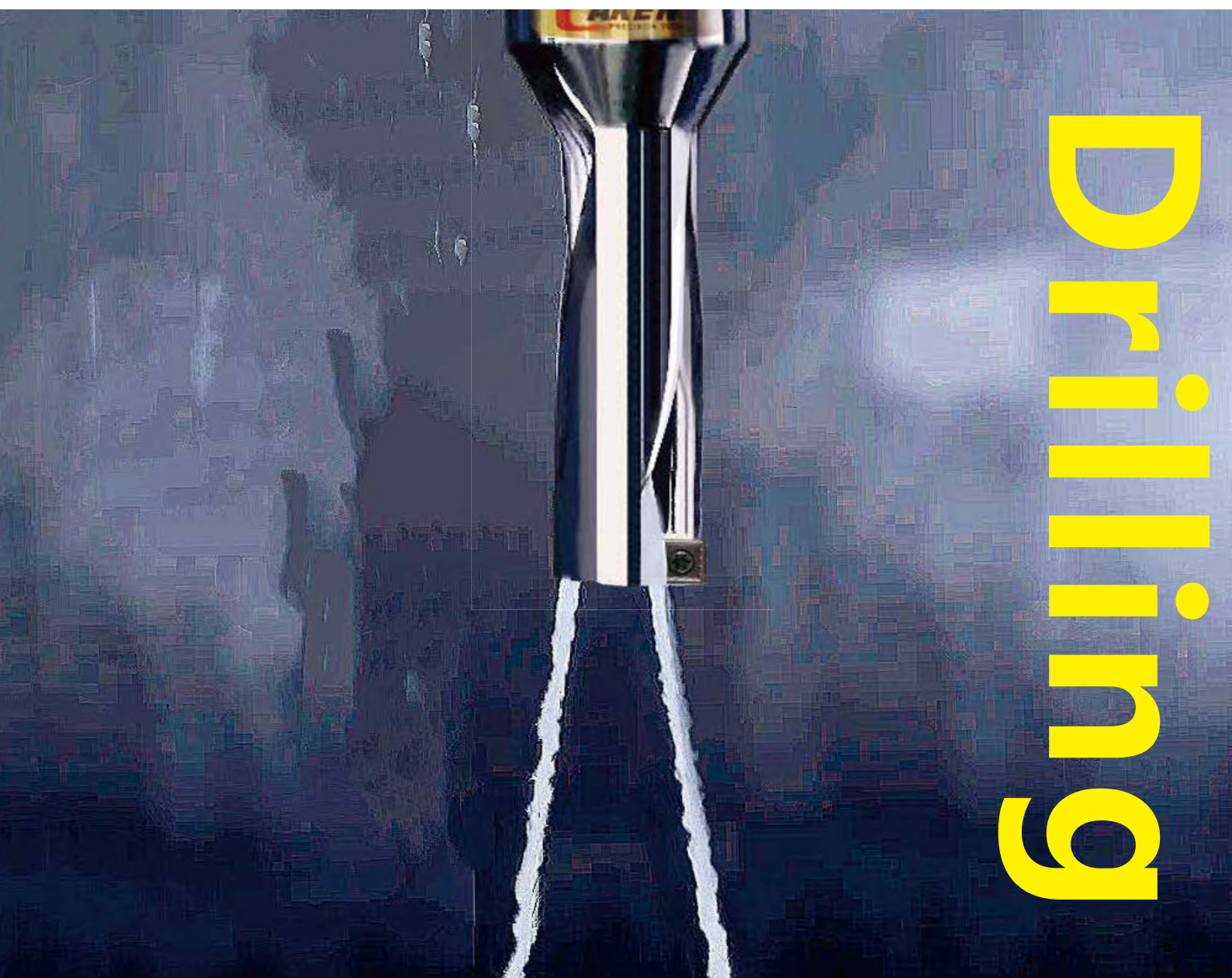

孔加工刀具

快速钻 Drilling



目录索引-1 按照刀具类别索引

快速钻

TOP 快速钻头-2D /3D	C002
TOP 快速钻头-4D /5D	C003
TDR 快速钻头-2D	C004
TDR 快速钻头-3D	C005
TDR 快速钻头-4D	C006
TDR 快速钻头-5D	C007
QSD 快速钻头-2D	C008
QSD 快速钻头-3D	C009
QSD 快速钻头-4D	C010
QSD 快速钻头-5D	C011
钻孔刀片	C012



TOP 快速钻头

2D/3D

加工范围：Φ14-26mm

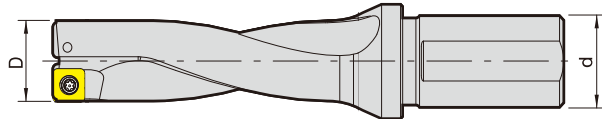

2XD

型号	尺寸		刀片	备件	
	D	d		螺钉	扳手
TOP 2140-20T2-05	14	20	SOMT050204 DP	R 20040 J	T6F
TOP 2145-20T2-05	14.5				
TOP 2150-20T2-05	15				
TOP 2155-20T2-05	15.5				
TOP 2160-20T2-05	16				
TOP 2165-25T2-06	16.5	25	SOMT060204 DP	R 22050 J	T7F
TOP 2170-25T2-06	17				
TOP 2175-25T2-06	17.5				
TOP 2180-25T2-06	18				
TOP 2185-25T2-06	18.5				
TOP 2190-25T2-06	19				
TOP 2195-25T2-07	19.5				
TOP 2200-25T2-07	20				
TOP 2205-25T2-07	20.5				
TOP 2210-25T2-07	21				
TOP 2215-25T2-07	21.5	25	SOMT070306 DP	R 25065 J	T8F
TOP 2220-25T2-07	22				
TOP 2225-25T2-08	22.5				
TOP 2230-25T2-08	23				
TOP 2235-25T2-08	23.5				
TOP 2240-25T2-08	24				
TOP 2245-25T2-08	24.5				
TOP 2250-25T2-08	25				
TOP 2255-25T2-08	25.5				
TOP 2260-25T2-08	26				

3XD

型号	尺寸		刀片	备件	
	D	d		螺钉	扳手
TOP 3140-20T2-05	14	20	SOMT050204 DP	R 20040 J	T6F
TOP 3145-20T2-05	14.5				
TOP 3150-20T2-05	15				
TOP 3155-20T2-05	15.5				
TOP 3160-20T2-05	16				
TOP 3165-25T2-06	16.5	25	SOMT060204 DP	R 22050 J	T7F
TOP 3170-25T2-06	17				
TOP 3175-25T2-06	17.5				
TOP 3180-25T2-06	18				
TOP 3185-25T2-06	18.5				
TOP 3190-25T2-06	19				
TOP 3195-25T2-07	19.5				
TOP 3200-25T2-07	20				
TOP 3205-25T2-07	20.5				
TOP 3210-25T2-07	21				
TOP 3215-25T2-07	21.5				
TOP 3220-25T2-07	22				
TOP 3225-25T2-08	22.5				
TOP 3230-25T2-08	23				
TOP 3235-25T2-08	23.5				
TOP 3240-25T2-08	24				
TOP 3245-25T2-08	24.5				
TOP 3250-25T2-08	25				
TOP 3255-25T2-08	25.5				
TOP 3260-25T2-08	26				

TOP 快速钻头

4D/5D

加工范围：Φ14-26mm

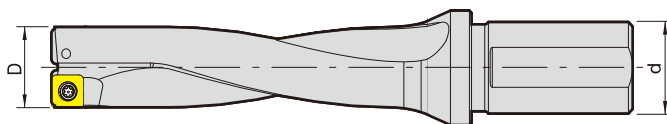

4XD

型号	尺寸		刀片	备件	
	D	d		螺钉	扳手
TOP 4140-20T2-05	14	20	SOMT050204 DP	R 20040J	T6F
TOP 4145-20T2-05	14.5				
TOP 4150-20T2-05	15				
TOP 4155-20T2-05	15.5				
TOP 4160-20T2-05	16				
TOP 4165-25T2-06	16.5	25	SOMT060204 DP	R 22050J	T7F
TOP 4170-25T2-06	17				
TOP 4175-25T2-06	17.5				
TOP 4180-25T2-06	18				
TOP 4185-25T2-06	18.5				
TOP 4190-25T2-06	19				
TOP 4195-25T2-07	19.5				
TOP 4200-25T2-07	20				
TOP 4205-25T2-07	20.5				
TOP 4210-25T2-07	21				
TOP 4215-25T2-07	21.5				
TOP 4220-25T2-07	22				
TOP 4225-25T2-08	22.5				
TOP 4230-25T2-08	23				
TOP 4235-25T2-08	23.5				
TOP 4240-25T2-08	24				
TOP 4245-25T2-08	24.5				
TOP 4250-25T2-08	25				
TOP 4255-25T2-08	25.5				
TOP 4260-25T2-08	26				
			SOMT070306 DP		
			SOMT08T306 DP	R 25065J	T8F

5XD

型号	尺寸		刀片	备件	
	D	d		螺钉	扳手
TOP 5140-20T2-05	14	20	SOMT050204 DP	R 20040J	T6F
TOP 5145-20T2-05	14.5				
TOP 5150-20T2-05	15				
TOP 5155-20T2-05	15.5				
TOP 5160-20T2-05	16				
TOP 5165-25T2-06	16.5	25	SOMT060204 DP	R 22050J	T7F
TOP 5170-25T2-06	17				
TOP 5175-25T2-06	17.5				
TOP 5180-25T2-06	18				
TOP 5185-25T2-06	18.5				
TOP 5190-25T2-06	19				
TOP 5195-25T2-07	19.5				
TOP 5200-25T2-07	20				
TOP 5205-25T2-07	20.5				
TOP 5210-25T2-07	21				
TOP 5215-25T2-07	21.5				
TOP 5220-25T2-07	22				
TOP 5225-25T2-08	22.5				
TOP 5230-25T2-08	23				
TOP 5235-25T2-08	23.5				
TOP 5240-25T2-08	24				
TOP 5245-25T2-08	24.5				
TOP 5250-25T2-08	25				
TOP 5255-25T2-08	25.5				
TOP 5260-25T2-08	26				
			SOMT070306 DP		
			SOMT08T306 DP	R 25065J	T8F

孔加工刀具 快速钻

TDR 快速钻头

2D

加工范围：Φ14-60m m

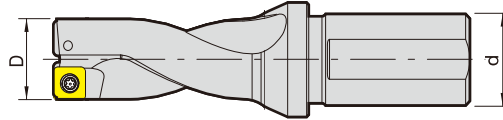

2XD

型号	尺寸		刀片	备件	
	D	d		螺钉	扳手
TDR 2140-25T2-05	14	25	SP □□050204	R 22050J	T6F
TDR 2145-25T2-05	14.5				
TDR 2150-25T2-05	15				
TDR 2155-25T2-05	15.5				
TDR 2160-25T2-06	16				
TDR 2165-25T2-06	16.5				
TDR 2170-25T2-06	17				
TDR 2175-25T2-06	17.5				
TDR 2180-25T2-06	18				
TDR 2185-25T2-06	18.5				
TDR 2190-25T2-06	19				
TDR 2195-25T2-06	19.5				
TDR 2200-25T2-06	20				
TDR 2205-25T2-06	20.5				
TDR 2210-25T2-06	21				
TDR 2215-25T2-06	21.5				
TDR 2220-25T2-07	22	32	SP □□060204	R 22060J	T7F
TDR 2225-25T2-07	22.5				
TDR 2230-25T2-07	23				
TDR 2235-25T2-07	23.5				
TDR 2240-25T2-07	24				
TDR 2245-25T2-07	24.5				
TDR 2250-25T2-07	25				
TDR 2255-25T2-07	25.5				
TDR 2260-32T2-07	26				
TDR 2265-32T2-07	26.5				
TDR 2270-32T2-07	27				
TDR 2275-32T2-07	27.5				
TDR 2280-32T2-09	28				
TDR 2285-32T2-09	28.5				
TDR 2290-32T2-09	29				
TDR 2295-32T2-09	29.5				
TDR 2300-32T2-09	30				
TDR 2305-32T2-09	30.5				
TDR 2310-32T2-09	31				
TDR 2315-32T2-09	31.5				
TDR 2320-32T2-09	32				
TDR 2325-32T2-09	32.5				
TDR 2330-32T2-09	33				
TDR 2335-32T2-09	33.5				
TDR 2340-32T2-11	34				
TDR 2345-32T2-11	34.5				
TDR 2350-32T2-11	35				
TDR 2355-32T2-11	35.5				
TDR 2360-32T2-11	36				
TDR 2365-32T2-11	36.5				
TDR 2370-32T2-11	37				
TDR 2375-32T2-11	37.5				
TDR 2380-32T2-11	38				
TDR 2385-32T2-11	38.5				
TDR 2390-32T2-11	39				
TDR 2395-32T2-11	39.5				
TDR 2400-32T2-11	40				
TDR 2405-32T2-11	40.5				
TDR 2410-32T2-11	41				
TDR 2415-32T2-11	41.5				
TDR 2420-40T2-14	42				
TDR 2425-40T2-14	42.5				
TDR 2430-40T2-14	43				
TDR 2435-40T2-14	43.5				
TDR 2440-40T2-14	44				
TDR 2445-40T2-14	44.5				
TDR 2450-40T2-14	45				
TDR 2455-40T2-14	45.5				
TDR 2460-40T2-14	46				
TDR 2465-40T2-14	46.5				
TDR 2470-40T2-14	47				
TDR 2475-40T2-14	47.5				
TDR 2480-40T2-14	48				
TDR 2485-40T2-14	48.5				
TDR 2490-40T2-14	49				
TDR 2495-40T2-14	49.5				
TDR 2500-40T2-14	50				
TDR 2510-40T2-07	51				
TDR 2515-40T2-07	51.5				
TDR 2520-40T2-07	52				
TDR 2525-40T2-07	52.5				
TDR 2530-40T2-07	53				
TDR 2535-40T2-07	53.5				
TDR 2540-40T2-07	54				
TDR 2545-40T2-07	54.5				
TDR 2550-40T2-07	55				
TDR 2560-40T2-09	56				
TDR 2565-40T2-09	56.5				
TDR 2570-40T2-09	57				
TDR 2575-40T2-09	57.5				
TDR 2580-40T2-09	58				
TDR 2585-40T2-09	58.5				
TDR 2590-40T2-09	59				
TDR 2595-40T2-09	59.5				
TDR 2600-40T2-09	60				

2XD

型号	尺寸		刀片	备件	
	D	d		螺钉	扳手
TDR 2370-32T2-11	37	32	SP □□110408	R 40100J	T15F
TDR 2375-32T2-11	37.5				
TDR 2380-32T2-11	38				
TDR 2385-32T2-11	38.5				
TDR 2390-32T2-11	39				
TDR 2395-32T2-11	39.5				
TDR 2400-32T2-11	40				
TDR 2405-32T2-11	40.5				
TDR 2410-32T2-11	41				
TDR 2415-32T2-11	41.5				
TDR 2420-40T2-14	42				
TDR 2425-40T2-14	42.5				
TDR 2430-40T2-14	43				
TDR 2435-40T2-14	43.5				
TDR 2440-40T2-14	44				
TDR 2445-40T2-14	44.5				
TDR 2450-40T2-14	45				
TDR 2455-40T2-14	45.5				
TDR 2460-40T2-14	46				
TDR 2465-40T2-14	46.5				
TDR 2470-40T2-14	47				
TDR 2475-40T2-14	47.5				
TDR 2480-40T2-14	48				
TDR 2485-40T2-14	48.5				
TDR 2490-40T2-14	49				
TDR 2495-40T2-14	49.5				
TDR 2500-40T2-14	50				
TDR 2510-40T2-07	51	40	SP □□140512	R 50120J	T20F
TDR 2515-40T2-07	51.5				
TDR 2520-40T2-07	52				
TDR 2525-40T2-07	52.5				
TDR 2530-40T2-07	53				
TDR 2535-40T2-07	53.5				
TDR 2540-40T2-07	54				
TDR 2545-40T2-07	54.5				
TDR 2550-40T2-07	55				
TDR 2560-40T2-09	56				
TDR 2565-40T2-09	56.5				
TDR 2570-40T2-09	57				
TDR 2575-40T2-09	57.5				
TDR 2580-40T2-09	58				
TDR 2585-40T2-09	58.5				
TDR 2590-40T2-09	59				
TDR 2595-40T2-09	59.5				
TDR 2600-40T2-09	60				
TDR 2370-32T2-11	37	32	SP □□07T308	R 25080G	T8F
TDR 2375-32T2-11	37.5				
TDR 2380-32T2-11	38				
TDR 2385-32T2-11	38.5				
TDR 2390-32T2-11	39				
TDR 2395-32T2-11	39.5				
TDR 2400-32T2-11	40				
TDR 2405-32T2-11	40.5				
TDR 2410-32T2-11	41				
TDR 2415-32T2-11	41.5				
TDR 2420-40T2-14	42				
TDR 2425-40T2-14	42.5				
TDR 2430-40T2-14	43				
TDR 2435-40T2-14	43.5				
TDR 2440-40T2-14	44				
TDR 2445-40T2-14	44.5				
TDR 2450-40T2-14	45				
TDR 2455-40T2-14	45.5				
TDR 2460-40T2-14	46				
TDR 2465-40T2-14	46.5				
TDR 2470-40T2-14	47				
TDR 2475-40T2-14	47.5				
TDR 2480-40T2-14	48				
TDR 2485-40T2-14	48.5				
TDR 2490-40T2-14	49				
TDR 2495-40T2-14	49.5				
TDR 2500-40T2-14	50				
TDR 2510-40T2-07	51	40	SP □□090408	R 35100J	T15F
TDR 2515-40T2-07	51.5				
TDR 2520-40T2-07	52				
TDR 2525-40T2-07	52.5				
TDR 2530-40T2-07	53				
TDR 2535-40T2-07	53.5				
TDR 2540-40T2-07	54				
TDR 2545-40T2-07	54.5				
TDR 2550-40T2-07	55				
TDR 2560-40T2-09	56				
TDR 2565-40T2-09	56.5				
TDR 2570-40T2-09	57				
TDR 2575-40T2-09	57.5				
TDR 2580-40T2-09	58				
TDR 2585-40T2-09	58.5				
TDR 2590-40T2-09	59				
TDR 2595-40T2-09	59.5				
TDR 2600-40T2-09	60				

孔加工刀具 快速钻

TDR 快速钻头

3D

加工范围：Φ14-60mm

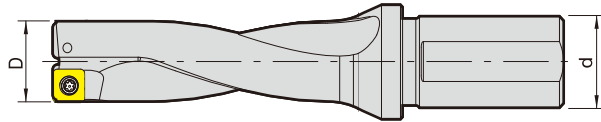

3XD

型号	尺寸		刀片	备件			
	D	d		螺钉	扳手		
TDR 3140-25T2-05	14	25	SP □□050204	R 22050J	T6F		
TDR 3145-25T2-05	14.5						
TDR 3150-25T2-05	15						
TDR 3155-25T2-05	15.5						
TDR 3160-25T2-06	16						
TDR 3165-25T2-06	16.5						
TDR 3170-25T2-06	17						
TDR 3175-25T2-06	17.5						
TDR 3180-25T2-06	18						
TDR 3185-25T2-06	18.5						
TDR 3190-25T2-06	19						
TDR 3195-25T2-06	19.5						
TDR 3200-25T2-06	20						
TDR 3205-25T2-06	20.5						
TDR 3210-25T2-06	21						
TDR 3215-25T2-06	21.5						
TDR 3220-25T2-07	22	SP □□060204	R 22060J	T7F			
TDR 3225-25T2-07	22.5						
TDR 3230-25T2-07	23						
TDR 3235-25T2-07	23.5						
TDR 3240-25T2-07	24						
TDR 3245-25T2-07	24.5						
TDR 3250-25T2-07	25						
TDR 3255-25T2-07	25.5						
TDR 3260-32T2-07	26				SP □□07T308	R 25080G	T8F
TDR 3265-32T2-07	26.5						
TDR 3270-32T2-07	27						
TDR 3275-32T2-07	27.5						
TDR 3280-32T2-09	28						
TDR 3285-32T2-09	28.5						
TDR 3290-32T2-09	29						
TDR 3295-32T2-09	29.5						
TDR 3300-32T2-09	30						
TDR 3305-32T2-09	30.5						
TDR 3310-32T2-09	31	SP □□090408	R 35100J	T15F			
TDR 3315-32T2-09	31.5						
TDR 3320-32T2-09	32						
TDR 3325-32T2-09	32.5						
TDR 3330-32T2-09	33						
TDR 3335-32T2-09	33.5						
TDR 3340-32T2-11	34				SP □□110408	R 40100J	T15F
TDR 3345-32T2-11	34.5						
TDR 3350-32T2-11	35						
TDR 3355-32T2-11	35.5						
TDR 3360-32T2-11	36						
TDR 3365-32T2-11	36.5						

3XD

型号	尺寸		刀片	备件					
	D	d		螺钉	扳手				
TDR 3370-32T2-11	37	32	SP □□110408	R 40100J	T15F				
TDR 3375-32T2-11	37.5								
TDR 3380-32T2-11	38								
TDR 3385-32T2-11	38.5								
TDR 3390-32T2-11	39								
TDR 3395-32T2-11	39.5								
TDR 3400-32T2-11	40								
TDR 3405-32T2-11	40.5								
TDR 3410-32T2-11	41								
TDR 3415-32T2-11	41.5								
TDR 3420-40T2-14	42					40	SP □□140512	R 50120J	T20F
TDR 3425-40T2-14	42.5								
TDR 3430-40T2-14	43								
TDR 3435-40T2-14	43.5								
TDR 3440-40T2-14	44								
TDR 3445-40T2-14	44.5								
TDR 3450-40T2-14	45								
TDR 3455-40T2-14	45.5								
TDR 3460-40T2-14	46								
TDR 3465-40T2-14	46.5								
TDR 3470-40T2-14	47								
TDR 3475-40T2-14	47.5								
TDR 3480-40T2-14	48								
TDR 3485-40T2-14	48.5								
TDR 3490-40T2-14	49								
TDR 3495-40T2-14	49.5								
TDR 3500-40T2-14	50	SP □□07T308	R 25080G	T8F					
TDR 3510-40T2-07	51								
TDR 3515-40T2-07	51.5								
TDR 3520-40T2-07	52								
TDR 3525-40T2-07	52.5								
TDR 3530-40T2-07	53								
TDR 3535-40T2-07	53.5								
TDR 3540-40T2-07	54								
TDR 3545-40T2-07	54.5								
TDR 3550-40T2-07	55				SP □□090408	R 35100J	T15F		
TDR 3560-40T2-09	56								
TDR 3565-40T2-09	56.5								
TDR 3570-40T2-09	57								
TDR 3575-40T2-09	57.5								
TDR 3580-40T2-09	58								
TDR 3585-40T2-09	58.5								
TDR 3590-40T2-09	59								
TDR 3595-40T2-09	59.5								
TDR 3600-40T2-09	60								

孔加工刀具 快速钻

TDR 快速钻头

4D

加工范围：Φ14-60m m

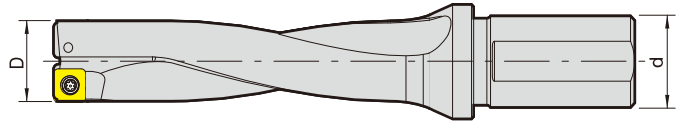

4XD

型号	尺寸		刀片	备件			
	D	d		螺钉	扳手		
TDR 4140-25T2-05	14	25	SP □□050204	R 22050J	T6F		
TDR 4145-25T2-05	14.5						
TDR 4150-25T2-05	15						
TDR 4155-25T2-05	15.5						
TDR 4160-25T2-06	16						
TDR 4165-25T2-06	16.5						
TDR 4170-25T2-06	17						
TDR 4175-25T2-06	17.5						
TDR 4180-25T2-06	18						
TDR 4185-25T2-06	18.5						
TDR 4190-25T2-06	19						
TDR 4195-25T2-06	19.5						
TDR 4200-25T2-06	20						
TDR 4205-25T2-06	20.5						
TDR 4210-25T2-06	21						
TDR 4215-25T2-06	21.5						
TDR 4220-25T2-07	22	SP □□060204	R 22060J	T7F			
TDR 4225-25T2-07	22.5						
TDR 4230-25T2-07	23						
TDR 4235-25T2-07	23.5						
TDR 4240-25T2-07	24						
TDR 4245-25T2-07	24.5						
TDR 4250-25T2-07	25						
TDR 4255-25T2-07	25.5						
TDR 4260-32T2-07	26				SP □□07T308	R 25080G	T8F
TDR 4265-32T2-07	26.5						
TDR 4270-32T2-07	27						
TDR 4275-32T2-07	27.5						
TDR 4280-32T2-09	28	SP □□090408	R 35100J	T15F			
TDR 4285-32T2-09	28.5						
TDR 4290-32T2-09	29						
TDR 4295-32T2-09	29.5						
TDR 4300-32T2-09	30						
TDR 4305-32T2-09	30.5						
TDR 4310-32T2-09	31						
TDR 4315-32T2-09	31.5						
TDR 4320-32T2-09	32						
TDR 4325-32T2-09	32.5						
TDR 4330-32T2-09	33	SP □□110408	R 40100J	T15F			
TDR 4335-32T2-09	33.5						
TDR 4340-32T2-11	34						
TDR 4345-32T2-11	34.5						
TDR 4350-32T2-11	35						
TDR 4355-32T2-11	35.5						
TDR 4360-32T2-11	36						
TDR 4365-32T2-11	36.5						

4XD

型号	尺寸		刀片	备件					
	D	d		螺钉	扳手				
TDR 4370-32T2-11	37	32	SP □□110408	R 40100J	T15F				
TDR 4375-32T2-11	37.5								
TDR 4380-32T2-11	38								
TDR 4385-32T2-11	38.5								
TDR 4390-32T2-11	39								
TDR 4395-32T2-11	39.5								
TDR 4400-32T2-11	40								
TDR 4405-32T2-11	40.5								
TDR 4410-32T2-11	41								
TDR 4415-32T2-11	41.5								
TDR 4420-40T2-14	42					40	SP □□140512	R 50120J	T20F
TDR 4425-40T2-14	42.5								
TDR 4430-40T2-14	43								
TDR 4435-40T2-14	43.5								
TDR 4440-40T2-14	44								
TDR 4445-40T2-14	44.5								
TDR 4450-40T2-14	45								
TDR 4455-40T2-14	45.5								
TDR 4460-40T2-14	46								
TDR 4465-40T2-14	46.5								
TDR 4470-40T2-14	47								
TDR 4475-40T2-14	47.5								
TDR 4480-40T2-14	48								
TDR 4485-40T2-14	48.5								
TDR 4490-40T2-14	49								
TDR 4495-40T2-14	49.5								
TDR 4500-40T2-14	50	SP □□07T308	R 25080G	T8F					
TDR 4510-40T2-07	51								
TDR 4515-40T2-07	51.5								
TDR 4520-40T2-07	52								
TDR 4525-40T2-07	52.5								
TDR 4530-40T2-07	53								
TDR 4535-40T2-07	53.5								
TDR 4540-40T2-07	54								
TDR 4545-40T2-07	54.5								
TDR 4550-40T2-07	55				SP □□090408	R 35100J	T15F		
TDR 4560-40T2-09	56								
TDR 4565-40T2-09	56.5								
TDR 4570-40T2-09	57								
TDR 4575-40T2-09	57.5								
TDR 4580-40T2-09	58								
TDR 4585-40T2-09	58.5								
TDR 4590-40T2-09	59								
TDR 4595-40T2-09	59.5								
TDR 4600-40T2-09	60								

孔加工刀具 快速钻

TDR 快速钻头

5D

加工范围：Φ14-60mm

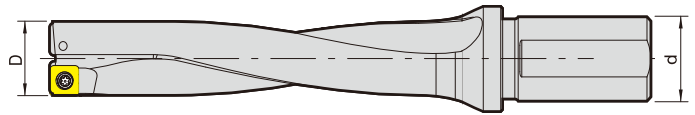

5XD

型号	尺寸		刀片	备件			
	D	d		螺钉	扳手		
TDR 5140-25T2-05	14	25	SP □□050204	R 22050J	T6F		
TDR 5145-25T2-05	14.5						
TDR 5150-25T2-05	15						
TDR 5155-25T2-05	15.5						
TDR 5160-25T2-06	16						
TDR 5165-25T2-06	16.5						
TDR 5170-25T2-06	17						
TDR 5175-25T2-06	17.5						
TDR 5180-25T2-06	18						
TDR 5185-25T2-06	18.5						
TDR 5190-25T2-06	19						
TDR 5195-25T2-06	19.5						
TDR 5200-25T2-06	20						
TDR 5205-25T2-06	20.5						
TDR 5210-25T2-06	21						
TDR 5215-25T2-06	21.5						
TDR 5220-25T2-07	22	SP □□060204	R 22060J	T7F			
TDR 5225-25T2-07	22.5						
TDR 5230-25T2-07	23						
TDR 5235-25T2-07	23.5						
TDR 5240-25T2-07	24						
TDR 5245-25T2-07	24.5						
TDR 5250-25T2-07	25						
TDR 5255-25T2-07	25.5						
TDR 5260-32T2-07	26				SP □□07T308	R 25080G	T8F
TDR 5265-32T2-07	26.5						
TDR 5270-32T2-07	27						
TDR 5275-32T2-07	27.5						
TDR 5280-32T2-09	28						
TDR 5285-32T2-09	28.5						
TDR 5290-32T2-09	29						
TDR 5295-32T2-09	29.5						
TDR 5300-32T2-09	30						
TDR 5305-32T2-09	30.5						
TDR 5310-32T2-09	31	SP □□090408	R 35100J	T15F			
TDR 5315-32T2-09	31.5						
TDR 5320-32T2-09	32						
TDR 5325-32T2-09	32.5						
TDR 5330-32T2-09	33						
TDR 5335-32T2-09	33.5						
TDR 5340-32T2-11	34				SP □□110408	R 40100J	T15F
TDR 5345-32T2-11	34.5						
TDR 5350-32T2-11	35						
TDR 5355-32T2-11	35.5						
TDR 5360-32T2-11	36						
TDR 5365-32T2-11	36.5						

5XD

型号	尺寸		刀片	备件				
	D	d		螺钉	扳手			
TDR 5370-32T2-11	37	32	SP □□110408	R 40100J	T15F			
TDR 5375-32T2-11	37.5							
TDR 5380-32T2-11	38							
TDR 5385-32T2-11	38.5							
TDR 5390-32T2-11	39							
TDR 5395-32T2-11	39.5							
TDR 5400-32T2-11	40							
TDR 5405-32T2-11	40.5							
TDR 5410-32T2-11	41							
TDR 5415-32T2-11	41.5							
TDR 5420-40T2-14	42	40	SP □□140512	R 50120J	T20F			
TDR 5425-40T2-14	42.5							
TDR 5430-40T2-14	43							
TDR 5435-40T2-14	43.5							
TDR 5440-40T2-14	44							
TDR 5445-40T2-14	44.5							
TDR 5450-40T2-14	45							
TDR 5455-40T2-14	45.5							
TDR 5460-40T2-14	46							
TDR 5465-40T2-14	46.5							
TDR 5470-40T2-14	47							
TDR 5475-40T2-14	47.5							
TDR 5480-40T2-14	48							
TDR 5485-40T2-14	48.5							
TDR 5490-40T2-14	49							
TDR 5495-40T2-14	49.5							
TDR 5500-40T2-14	50							
TDR 5510-40T2-07	51					SP □□07T308	R 25080G	T8F
TDR 5515-40T2-07	51.5							
TDR 5520-40T2-07	52							
TDR 5525-40T2-07	52.5							
TDR 5530-40T2-07	53							
TDR 5535-40T2-07	53.5							
TDR 5540-40T2-07	54							
TDR 5545-40T2-07	54.5							
TDR 5550-40T2-07	55							
TDR 5560-40T2-09	56	SP □□090408	R 35100J	T15F				
TDR 5565-40T2-09	56.5							
TDR 5570-40T2-09	57							
TDR 5575-40T2-09	57.5							
TDR 5580-40T2-09	58							
TDR 5585-40T2-09	58.5							
TDR 5590-40T2-09	59							
TDR 5595-40T2-09	59.5							
TDR 5600-40T2-09	60							

孔加工刀具 快速钻

QSD 快速钻头

2D

加工范围: $\Phi 16-74\text{mm}$

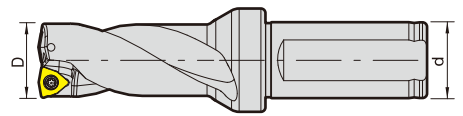

2XD

型号	尺寸		刀片	备件	
	D	d		螺钉	扳手
QSD 16-32-C25	16	25	W CM X030208	R 25050G	T8F
QSD 16.5-33-C25	16.5				
QSD 17-34-C25	17				
QSD 17.5-35-C25	17.5				
QSD 18-36-C25	18				
QSD 18.5-37-C25	18.5				
QSD 19-38-C25	19				
QSD 19.5-39-C25	19.5				
QSD 20-40-C25	20				
QSD 20.5-41-C25	20.5				
QSD 21-42-C25	21				
QSD 21.5-43-C25	21.5				
QSD 22-44-C25	22				
QSD 22.5-45-C25	22.5				
QSD 23-46-C25	23				
QSD 23.5-47-C25	23.5				
QSD 24-48-C25	24				
QSD 24.5-49-C25	24.5				
QSD 25-50-C25	25	32	W CM X050308	R 30080E	T8F
QSD 25.5-51-C25	25.5				
QSD 26-52-C32	26				
QSD 26.5-53-C32	26.5				
QSD 27-54-C32	27				
QSD 27.5-55-C32	27.5				
QSD 28-56-C32	28				
QSD 28.5-57-C32	28.5				
QSD 29-58-C32	29				
QSD 29.5-59-C32	29.5				
QSD 30-60-C32	30				
QSD 30.5-61-C32	30.5				
QSD 31-62-C32	31				
QSD 31.5-63-C32	31.5				
QSD 32-64-C32	32				
QSD 32.5-65-C32	32.5				
QSD 33-66-C32	33				
QSD 33.5-67-C32	33.5				
QSD 34-68-C32	34				
QSD 34.5-69-C32	34.5				
QSD 35-70-C32	35				
QSD 35.5-71-C32	35.5				
QSD 36-72-C32	36				
QSD 36.5-73-C32	36.5				
QSD 37-74-C32	37				
QSD 37.5-75-C32	37.5				
QSD 38-76-C32	38				
QSD 38.5-77-C32	38.5				
QSD 39-78-C32	39				
QSD 39.5-79-C32	39.5				
QSD 40-80-C32	40				
QSD 40.5-81-C32	40.5				
QSD 41-82-C32	41				
QSD 41.5-83-C32	41.5				
QSD 42-84-C40	42	40	W CM X080412	R 40100J	T15F
QSD 42.5-85-C40	42.5				
QSD 43-86-C40	43				

2XD

型号	尺寸		刀片	备件		
	D	d		螺钉	扳手	
QSD 43.5-87-C40	43.5	40	W CM X080412	R 40100J	T15F	
QSD 44-88-C40	44					
QSD 44.5-89-C40	44.5					
QSD 45-90-C40	45					
QSD 45.5-91-C40	45.5					
QSD 46-92-C40	46					
QSD 46.5-93-C40	46.5					
QSD 47-94-C40	47					
QSD 47.5-95-C40	47.5					
QSD 48-96-C40	48					
QSD 48.5-97-C40	48.5					
QSD 49-98-C40	49					
QSD 49.5-99-C40	49.5					
QSD 50-100-C40	50					
QSD 50.5-101-C40	50.5					
QSD 51-102-C40	51					
QSD 51.5-103-C40	51.5					
QSD 52-104-C40	52					
QSD 52.5-105-C40	52.5					
QSD 53-106-C40	53					
QSD 53.5-107-C40	53.5					
QSD 54-108-C40	54					
QSD 54.5-109-C40	54.5					
QSD 55-110-C40	55					
QSD 55.5-111-C40	55.5					
QSD 56-112-C40	56					
QSD 56.5-113-C40	56.5					
QSD 57-114-C40	57					
QSD 57.5-115-C40	57.5					
QSD 58-116-C40	58					
QSD 58.5-117-C40	58.5					
QSD 59-118-C40	59					
QSD 59-118-C50	59	50				
QSD 59.5-119-C40	59.5	40	W CM X050308	R 30080E	T8F	
QSD 60-120-C40	60					
QSD 61-122-C40	61					
QSD 61.5-123-C40	61.5					
QSD 62-124-C40	62					
QSD 62.5-125-C40	62.5					
QSD 63-126-C40	63					
QSD 64-128-C40	64					
QSD 64-128-C50	64					50
QSD 64.5-129-C40	64.5					
QSD 65-130-C40	65					
QSD 65.5-131-C40	65.5					
QSD 66-132-C40	66					
QSD 66.5-133-C40	66.5					
QSD 67-134-C40	67					
QSD 67.5-135-C40	67.5					
QSD 68-136-C40	68					
QSD 68.5-137-C40	68.5					
QSD 69-138-C40	69					
QSD 69.5-139-C40	69.5					
QSD 70-140-C40	70					
QSD 74-148-C50	74	50	W CM X6T308	R 35100J	T15F	

孔加工刀具 快速钻

QSD 快速钻头

3D

加工范围: $\Phi 16-87\text{mm}$

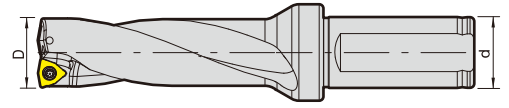

3XD

型号	尺寸		刀片	备件	
	D	d		螺钉	扳手
QSD 16-48-C25	16	25	W CM X030208	R 25050G	T8F
QSD 16.5-50-C25	16.5				
QSD 17-51-C25	17				
QSD 17.5-53-C25	17.5				
QSD 18-54-C25	18				
QSD 18.5-56-C25	18.5				
QSD 19-57-C25	19				
QSD 19.5-59-C25	19.5				
QSD 20-60-C25	20				
QSD 20.5-62-C25	20.5				
QSD 21-63-C25	21				
QSD 21.5-65-C25	21.5				
QSD 22-66-C25	22				
QSD 22.5-68-C25	22.5				
QSD 23-69-C25	23				
QSD 23.5-71-C25	23.5				
QSD 24-72-C25	24				
QSD 24.5-74-C25	24.5				
QSD 25-75-C25	25				
QSD 25.5-77-C25	25.5				
QSD 26-78-C32	26	32	W CM X050308	R 30080E	T8F
QSD 26.5-80-C32	26.5				
QSD 27-81-C32	27				
QSD 27.5-83-C32	27.5				
QSD 28-84-C32	28				
QSD 28.5-86-C32	28.5				
QSD 29-87-C32	29				
QSD 29.5-89-C32	29.5				
QSD 30-90-C32	30				
QSD 30.5-92-C32	30.5				
QSD 31-93-C32	31				
QSD 31.5-95-C32	31.5				
QSD 32-96-C32	32				
QSD 32.5-98-C32	32.5				
QSD 33-99-C32	33				
QSD 33.5-101-C32	33.5				
QSD 34-102-C32	34				
QSD 34.5-104-C32	34.5				
QSD 35-105-C32	35				
QSD 35.5-107-C32	35.5				
QSD 36-108-C32	36				
QSD 36.5-110-C32	36.5				
QSD 37-111-C32	37				
QSD 37.5-113-C32	37.5				
QSD 38-114-C32	38				
QSD 38.5-116-C32	38.5				
QSD 39-117-C32	39				
QSD 39.5-119-C32	39.5				
QSD 40-120-C32	40				
QSD 40.5-122-C32	40.5				
QSD 41-123-C32	41				
QSD 41.5-125-C32	41.5				
QSD 42-126-C40	42	40	W CM X080412	R 40100J	T15F
QSD 42.5-128-C40	42.5				
QSD 43-129-C40	43				
QSD 43.5-131-C40	43.5				

3XD

型号	尺寸		刀片	备件	
	D	d		螺钉	扳手
QSD 44-132-C40	44	40	W CM X080412	R 40100J	T15F
QSD 44.5-134-C40	44.5				
QSD 45-135-C40	45				
QSD 45.5-137-C40	45.5				
QSD 46-138-C40	46				
QSD 46.5-140-C40	46.5				
QSD 47-141-C40	47				
QSD 47.5-143-C40	47.5				
QSD 48-144-C40	48				
QSD 48.5-146-C40	48.5				
QSD 49-147-C40	49				
QSD 49.5-149-C40	49.5				
QSD 50-150-C40	50				
QSD 50.5-152-C40	50.5				
QSD 51-153-C40	51				
QSD 51.5-155-C40	51.5				
QSD 52-156-C40	52				
QSD 52.5-158-C40	52.5				
QSD 53-159-C40	53				
QSD 53.5-161-C40	53.5				
QSD 54-162-C40	54				
QSD 54.5-164-C40	54.5				
QSD 55-165-C40	55				
QSD 55.5-167-C40	55.5				
QSD 56-168-C40	56				
QSD 56.5-170-C40	56.5				
QSD 57-171-C40	57				
QSD 57.5-173-C40	57.5				
QSD 58-174-C40	58				
QSD 58.5-176-C40	58.5				
QSD 59-177-C40	59				
QSD 59.5-179-C40	59.5				
QSD 60-180-C40	60				
QSD 61-183-C40	61	40	W CM X050308	R 30080E	T8F
QSD 61.5-185-C40	61.5				
QSD 62-186-C40	62				
QSD 62.5-188-C40	62.5				
QSD 63-189-C40	63				
QSD 64-192-C40	64				
QSD 64.5-194-C40	64.5				
QSD 65-195-C40	65				
QSD 65.5-197-C40	65.5				
QSD 66-198-C40	66				
QSD 66.5-200-C40	66.5				
QSD 67-201-C40	67				
QSD 67-201-C50	67				
QSD 67.5-203-C40	67.5				
QSD 68-204-C40	68				
QSD 68-204-C50	68				
QSD 68.5-206-C40	68.5				
QSD 69-207-C40	69				
QSD 69.5-209-C40	69.5				
QSD 70-210-C40	70				
QSD 77-231-C50	70				
QSD 87-261-C50	87				

孔加工刀具 快速钻

QSD 快速钻头

4D

加工范围: $\Phi 16-70\text{mm}$

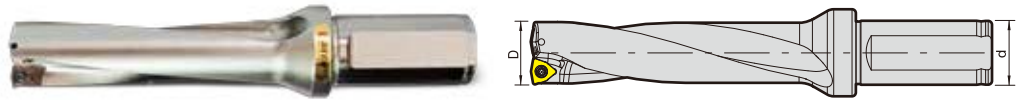

4XD

型号	尺寸		刀片	备件	
	D	d		螺钉	扳手
QSD 16-64-C25	16	25	WCM X030208	R25050G	T8F
QSD 16.5-66-C25	16.5				
QSD 17-68-C25	17				
QSD 17.5-70-C25	17.5				
QSD 18-72-C25	18				
QSD 18.5-74-C25	18.5				
QSD 19-76-C25	19				
QSD 19.5-78-C25	19.5				
QSD 20-80-C25	20				
QSD 20.5-82-C25	20.5				
QSD 21-84-C25	21				
QSD 21.5-86-C25	21.5				
QSD 22-88-C25	22				
QSD 22.5-90-C25	22.5				
QSD 23-92-C25	23				
QSD 23.5-94-C25	23.5				
QSD 24-96-C25	24				
QSD 24.5-98-C25	24.5				
QSD 25-100-C25	25				
QSD 25.5-102-C25	25.5				
QSD 26-104-C32	26	32	WCM X050308	R30080E	T8F
QSD 26.5-106-C32	26.5				
QSD 27-108-C32	27				
QSD 27.5-110-C32	27.5				
QSD 28-112-C32	28				
QSD 28.5-114-C32	28.5				
QSD 29-116-C32	29				
QSD 29.5-118-C32	29.5				
QSD 30-120-C32	30				
QSD 30.5-122-C32	30.5				
QSD 31-124-C32	31				
QSD 31.5-126-C32	31.5				
QSD 32-128-C32	32				
QSD 32.5-130-C32	32.5				
QSD 33-132-C32	33				
QSD 33.5-134-C32	33.5				
QSD 34-136-C32	34				
QSD 34.5-138-C32	34.5				
QSD 35-140-C32	35				
QSD 35.5-142-C32	35.5				
QSD 36-144-C32	36				
QSD 36.5-146-C32	36.5				
QSD 37-148-C32	37				
QSD 37.5-150-C32	37.5				
QSD 38-152-C32	38				
QSD 38.5-154-C32	38.5				
QSD 39-156-C32	39				
QSD 39.5-158-C32	39.5				
QSD 40-160-C32	40				
QSD 40.5-162-C32	40.5				
QSD 41-164-C32	41				
QSD 41.5-166-C32	41.5				
QSD 42-168-C40	42	40	WCM X080412	R40100J	T15F
QSD 42.5-170-C40	42.5				
QSD 43-172-C40	43				

4XD

型号	尺寸		刀片	备件		
	D	d		螺钉	扳手	
QSD 43.5-174-C40	43.5	40	WCM X080412	R40100J	T15F	
QSD 44-176-C40	44					
QSD 44.5-178-C40	44.5					
QSD 45-180-C40	45					
QSD 45.5-182-C40	45.5					
QSD 46-184-C40	46					
QSD 46.5-186-C40	46.5					
QSD 47-188-C32	47					32
QSD 47-188-C40	47					
QSD 47.5-190-C40	47.5					40
QSD 48-192-C40	48					
QSD 48.5-194-C40	48.5					
QSD 49-196-C40	49					
QSD 49.5-198-C40	49.5					
QSD 50-200-C40	50					
QSD 50.5-202-C40	50.5					
QSD 51-204-C40	51					
QSD 51.5-206-C40	51.5					
QSD 52-208-C40	52					
QSD 52.5-210-C40	52.5					
QSD 53-212-C40	53					
QSD 53.5-214-C40	53.5					
QSD 54-216-C40	54					
QSD 54.5-218-C40	54.5					
QSD 55-220-C40	55					
QSD 55.5-222-C40	55.5					
QSD 56-224-C40	56					
QSD 56.5-226-C40	56.5					
QSD 57-228-C40	57					
QSD 57.5-230-C40	57.5					
QSD 58-232-C40	58					
QSD 58.5-234-C40	58.5					
QSD 59-236-C40	59					
QSD 59.5-238-C40	59.5					
QSD 60-240-C40	60					
QSD 61-244-C40	61					
QSD 61.5-246-C40	61.5					
QSD 62-248-C40	62					
QSD 62.5-250-C40	62.5					
QSD 63-252-C40	63					
QSD 63-252-C50	63	50				
QSD 64-256-C40	64					
QSD 64.5-258-C40	64.5					
QSD 65-260-C40	65					
QSD 65.5-262-C40	65.5					
QSD 66-264-C40	66					
QSD 66.5-266-C40	66.5					
QSD 67-268-C40	67					
QSD 67.5-270-C40	67.5					
QSD 68-272-C40	68					
QSD 68.5-274-C40	68.5					
QSD 69-276-C40	69					
QSD 69.5-278-C40	69.5					
QSD 70-280-C40	70					

孔加工刀具 快速钻

QSD 快速钻头

5D

加工范围: $\Phi 16-70\text{mm}$

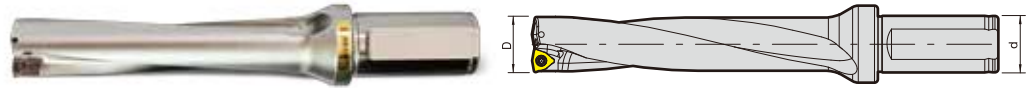

5XD

型号	尺寸		刀片	备件	
	D	d		螺钉	扳手
QSD 16-80-C25	16	25	WCMX030208	R25050G	T8F
QSD 16.5-83-C25	16.5				
QSD 17-85-C25	17				
QSD 17.5-88-C25	17.5				
QSD 18-90-C25	18				
QSD 18.5-93-C25	18.5				
QSD 19-95-C25	19				
QSD 19.5-98-C25	19.5				
QSD 20-100-C25	20				
QSD 20.5-103-C25	20.5				
QSD 21-105-C25	21				
QSD 21.5-108-C25	21.5				
QSD 22-110-C25	22				
QSD 22.5-113-C25	22.5				
QSD 23-115-C25	23				
QSD 23.5-118-C25	23.5				
QSD 24-120-C25	24	32	WCMX050308	R30080E	T8F
QSD 24.5-123-C25	24.5				
QSD 25-125-C25	25				
QSD 25.5-128-C25	25.5				
QSD 26-130-C32	26				
QSD 26.5-133-C32	26.5				
QSD 27-135-C32	27				
QSD 27.5-138-C32	27.5				
QSD 28-140-C32	28				
QSD 28.5-143-C32	28.5				
QSD 29-145-C32	29				
QSD 29.5-148-C32	29.5				
QSD 30-150-C32	30				
QSD 30.5-153-C32	30.5				
QSD 31-155-C32	31				
QSD 31.5-158-C32	31.5				
QSD 32-160-C32	32				
QSD 32.5-163-C32	32.5				
QSD 33-165-C32	33				
QSD 33.5-168-C32	33.5				
QSD 34-170-C32	34				
QSD 34.5-173-C32	34.5				
QSD 35-175-C32	35				
QSD 35.5-178-C32	35.5				
QSD 36-180-C32	36				
QSD 36.5-183-C32	36.5				
QSD 37-185-C32	37				
QSD 37.5-188-C32	37.5				
QSD 38-190-C32	38				
QSD 38.5-193-C32	38.5				
QSD 39-195-C32	39				
QSD 39.5-198-C32	39.5				
QSD 40-200-C32	40				
QSD 40.5-203-C32	40.5				
QSD 41-205-C32	41				
QSD 41.5-208-C32	41.5				
QSD 42-210-C40	42	40	WCMX080412	R40100J	T15F
QSD 42.5-213-C40	42.5				

5XD

型号	尺寸		刀片	备件	
	D	d		螺钉	扳手
QSD 43-215-C40	43	40	WCMX080412	R40100J	T15F
QSD 43.5-218-C40	43.5				
QSD 44-220-C40	44				
QSD 44.5-223-C40	44.5				
QSD 45-225-C40	45				
QSD 45.5-228-C40	45.5				
QSD 46-230-C40	46				
QSD 46.5-233-C40	46.5				
QSD 47-235-C40	47				
QSD 47.5-238-C40	47.5				
QSD 48-240-C40	48				
QSD 48.5-243-C40	48.5				
QSD 49-245-C40	49				
QSD 49.5-248-C40	49.5				
QSD 50-250-C40	50				
QSD 50.5-253-C40	50.5				
QSD 51-255-C40	51				
QSD 51.5-258-C40	51.5				
QSD 52-260-C40	52				
QSD 52.5-263-C40	52.5				
QSD 53-265-C40	53				
QSD 53.5-268-C40	53.5				
QSD 54-270-C40	54				
QSD 54.5-273-C40	54.5				
QSD 55-275-C40	55				
QSD 55.5-278-C40	55.5				
QSD 56-280-C40	56				
QSD 56.5-283-C40	56.5				
QSD 57-285-C40	57				
QSD 57.5-288-C40	57.5				
QSD 58-290-C40	58				
QSD 58.5-292-C40	58.5				
QSD 59-295-C40	59				
QSD 59.5-298-C40	59.5				
QSD 60-300-C40	60				
QSD 61-305-C40	61				
QSD 61.5-308-C40	61.5				
QSD 62-310-C40	62				
QSD 62.5-313-C40	62.5				
QSD 63-315-C40	63				
QSD 64-320-C40	64				
QSD 64.5-323-C40	64.5				
QSD 65-325-C40	65				
QSD 65.5-328-C40	65.5				
QSD 66-330-C40	66				
QSD 66.5-333-C40	66.5				
QSD 67-335-C40	67				
QSD 67.5-338-C40	67.5				
QSD 68-340-C40	68				
QSD 68.5-343-C40	68.5				
QSD 69-345-C40	69				
QSD 69.5-348-C40	69.5				
QSD 70-350-C40	70				
QSD 70.5-353-C40	70.5				
QSD 71-355-C40	71				
QSD 71.5-358-C40	71.5				
QSD 72-360-C40	72				
QSD 72.5-363-C40	72.5				
QSD 73-365-C40	73				
QSD 73.5-368-C40	73.5				
QSD 74-370-C40	74				
QSD 74.5-373-C40	74.5				
QSD 75-375-C40	75				
QSD 75.5-378-C40	75.5				
QSD 76-380-C40	76				
QSD 76.5-383-C40	76.5				
QSD 77-385-C40	77				
QSD 77.5-388-C40	77.5				
QSD 78-390-C40	78				
QSD 78.5-393-C40	78.5				
QSD 79-395-C40	79				
QSD 79.5-398-C40	79.5				
QSD 80-400-C40	80				
QSD 80.5-403-C40	80.5				
QSD 81-405-C40	81				
QSD 81.5-408-C40	81.5				
QSD 82-410-C40	82				
QSD 82.5-413-C40	82.5				
QSD 83-415-C40	83				
QSD 83.5-418-C40	83.5				
QSD 84-420-C40	84				
QSD 84.5-423-C40	84.5				
QSD 85-425-C40	85				
QSD 85.5-428-C40	85.5				
QSD 86-430-C40	86				
QSD 86.5-433-C40	86.5				
QSD 87-435-C40	87				
QSD 87.5-438-C40	87.5				
QSD 88-440-C40	88				
QSD 88.5-443-C40	88.5				
QSD 89-445-C40	89				
QSD 89.5-448-C40	89.5				
QSD 90-450-C40	90				
QSD 90.5-453-C40	90.5				
QSD 91-455-C40	91				
QSD 91.5-458-C40	91.5				
QSD 92-460-C40	92				
QSD 92.5-463-C40	92.5				
QSD 93-465-C40	93				
QSD 93.5-468-C40	93.5				
QSD 94-470-C40	94				
QSD 94.5-473-C40	94.5				
QSD 95-475-C40	95				
QSD 95.5-478-C40	95.5				
QSD 96-480-C40	96				
QSD 96.5-483-C40	96.5				
QSD 97-485-C40	97				
QSD 97.5-488-C40	97.5				
QSD 98-490-C40	98				
QSD 98.5-493-C40	98.5				
QSD 99-495-C40	99				
QSD 99.5-498-C40	99.5				
QSD 100-500-C40	100				
QSD 100.5-503-C40	100.5				
QSD 101-505-C40	101				
QSD 101.5-508-C40	101.5				
QSD 102-510-C40	102				
QSD 102.5-513-C40	102.5				
QSD 103-515-C40	103				
QSD 103.5-518-C40	103.5				
QSD 104-520-C40	104				
QSD 104.5-523-C40	104.5				
QSD 105-525-C40	105				
QSD 105.5-528-C40	105.5				
QSD 106-530-C40	106				
QSD 106.5-533-C40	106.5				
QSD 107-535-C40	107				
QSD 107.5-538-C40	107.5				
QSD 108-540-C40	108				
QSD 108.5-543-C40	108.5				
QSD 109-545-C40	109				
QSD 109.5-548-C40	109.5				
QSD 110-550-C40	110				
QSD 110.5-553-C40	110.5				
QSD 111-555-C40	111				
QSD 111.5-558-C40	111.5				
QSD 112-560-C40	112				
QSD 112.5-563-C40	112.5				
QSD 113-565-C40	113				
QSD 113.5-568-C40	113.5				
QSD 114-570-C40	114				
QSD 114.5-573-C40	114.5				
QSD 115-575-C40	115				
QSD 115.5-578-C40	115.5				
QSD 116-580-C40	116				
QSD 116.5-583-C40	116.5				
QSD 117-585-C40	117				
QSD 117.5-588-C40	117.5				
QSD 118-590-C40	118				
QSD 118.5-593-C40	118.5				
QSD 119-595-C40	119				
QSD 119.5-598-C40	119.5				
QSD 120-600-C40	120				
QSD 120.5-603-C40	120.5				
QSD 121-605-C40	121				
QSD 121.5-608-C40	121.5				
QSD 122-610-C40	122				
QSD 122.5-613-C40	122.5				
QSD 123-615-C40	123				
QSD 123.5-618-C40	123.5				
QSD 124-620-C40	124				
QSD 124.5-623-C40	124.5				
QSD 125-625-C40	125				
QSD 125.5-628-C40	125.5				
QSD 126-630-C40	126				
QSD 126.5-633-C40	126.5				
QSD 127-635-C40	127				
QSD 127.5-638-C40	127.5				
QSD 128-640-C40	128				
QSD 128.5-643-C40	128.5				
QSD 129-645-C40	129				
QSD 129.5-648-C40	129.5				
QSD 130-650-C40	130				
QSD 130.5-653-C40	130.5				
QSD 131-655-C40	131				
QSD 131.5-658-C40	131.5				
QSD 132-660-C40	132				
QSD 132.5-663-C40	132.5				
QSD 133-665-C40	133				
QSD 133.5-668-C40	133.5				
QSD 134-670-C40	134				
QSD 134.5-673-C40	134.5				
QSD 135-675-C40	135				
QSD 135.5-678-C40	135.5				
QSD 136-680-C40	136				
QSD 136.5-683-C40	136.5				
QSD 137-685-C40	137				
QSD 137.5-688-C40	137.5				
QSD 138-690-C40	138				
QSD 138.5-693-C40	138.5				
QSD 139-695-C40	139				
QSD 139.5-698-C40	139.5				
QSD 140-700-C40	140				
QSD 140.5-703-C40	140.5				
QSD 141-705-C40	141				
QSD 141.5-708-C40	141.5				
QSD 142-710-C40	142				
QSD 142.5-713-C40	142.5				
QSD 143-715-C40	143				
QSD 143.5-718-C40	143.5				
QSD 144-720-C40	144				
QSD 144.5-723-C40	144.5				
QSD 145-725-C40	145				
QSD 145.5-728-C40	145.5				
QSD 146-730-C40	146				
QSD 146.5-733-C40	146.5				
QSD 147-735-C40	147				
QSD 147.5-738-C40	147.5				
QSD 148-740-C40	148				
QSD 148.5-743-C40	148.5				
QSD 149-745-C40	149				
QSD 149.5-748-C40	149.5				
QSD 150-750-C40	150				
QSD 150.5-753-C40	150.5				
QSD 151-755-C40	151				
QSD 151.5-758-C40	151.5				
QSD 152-760-C40	152				
QSD 152.5-763-C40	152.5				
QSD 153-765-C40	153				
QSD 153.5-768-C40	153.5				
QSD 154-770-C40	154				
QSD 154.5-773-C40	154.5				
QSD 155-775-C40	155				
QSD 155.5-778-C40	155.5				
QSD 156-780-C40	156				
QSD 156.5-783-C40	156.5				
QSD 157-785-C40	157				
QSD 157.5-788-C40	157.5				
QSD 158-790-C40	158				
QSD 158.5-793-C40	158.5				
QSD 159-795-C40	159				
QSD 159.5-798-C40	159.5				
QSD 160-800-C40	160				
QSD 160.5-803-C40	160.5				
QSD 161-805-C40	161				
QSD 161.5-808-C40	161.5				
QSD 162-810-C40	162				
QSD 162.5-813-C40	162.5				
QSD 163-815-C40	163				
QSD 163.5-818-C40	163.5				
QSD 164-820-C40	164				
QSD 164.5-823-C40	164.5				
QSD 165-825-C40	165				
QSD 165.5-828-C40	165.5				
QSD 166-830-C40	166				
QSD 166.5-833-C40	166.5				
QSD 167-835-C40	167				
QSD 167.5-838-C40	167.5				
QSD 168-840-C40	168				
QSD 168.5-843-C40	168.5				
QSD 169-845-C40	169				
QSD 169.5-848-C40	169.5				
QSD 170-850-C40	170				
QSD 170.5-853-C40	170.5				
QSD 171-855-C40	171				
QSD 171.5-858-C40	171.5				
QSD 172-860-C40	172				
QSD 172.5-863-C40	172.5				
QSD 173-865-C40	173				
QSD 173.5-868-C40	173.5				
QSD 174-870-C40	174				
QSD 174.5-873-C40	174.5				
QSD 175-875-C40	175				
QSD 175.5-878-C40	175.5				
QSD 176-880-C40	176				
QSD 176.5-883-C40	176.5				
QSD 177-885-C40	177				
QSD 177.5-888-C40	177.5				
QSD 178-890-C40	178				
QSD 178.5-893-C40	178.5				
QSD 179-895-C40	179				
QSD 179.5-898-C40	179.5				
QSD 180-900-C40	180				
QSD 180.5-903-C40	180.5				
QSD 181-905-C40	181				
QSD 181.5-908-C40	181.5				
QSD 182-910-C40	182				
QSD 182.5-913-C40	182.5				
QSD 183-915-C40	183				
QSD 183.5-918-C40	183.5				
QSD 184-920-C40	184				
QSD 184.5-923-C40	184.5				
QSD 185-925-C40	185				
QSD 185.5-928-C40	185.5				
QSD 186-930-C40	186				
QSD 186.5-933-C40	186.5				
QSD 187-935-C40	187				
QSD 187.5-938-C40	187.5				
QSD 188-940-C40	188				
QSD 188.5-943-C40	188.5				
QSD 189-945-C40	189				
QSD 189.5-948-C40	189.5				
QSD 190-950-C40	190				
QSD 190.5-953-C40	190.5				
QSD 191-955-C40	191				
QSD 191.5-958-C40	191.5				
QSD 192-960-C40	192				
QSD 192.5-963-C40	192.5				
QSD 193-965-C40	193				
QSD 193.5-968-C40	193.5				
QSD 194-970-C40	194				
QSD 194.5-973-C40	194.5				
QSD 195-975-C40	195				
QSD 195.5-978-C40	195.5				
QSD 196-980-C40	196				
QSD 196.5-983-C					

钻孔刀片

SOMT □□□□□□ (快速钻)

▲良好

△一般

	工件材质	P 中低硬度钢	△												
		P 高硬度钢、合金钢	▲	▲											
		M 不锈钢	▲	▲											
		K 铸铁	▲												
		N 有色金属													
		S 耐热合金													
		刀片基本尺寸				PVD涂层					CVD涂层			硬质合金	
D	d	S	R	PM8120	PM8125	PP8020	PP8030	KP1015	PC4115	PC4125	KC1015	KC1025	HI101		
SOMT050204	4.9	2.25	2.38	0.4	●	●									
SOMT060204	5.7	2.6	2.38	0.4	●	●									
SOMT070306	6.8	2.6	2.8	0.6	●	●									
SOMT08T306	7.9	2.85	3.9	0.6	●	●									
SOMT09T308	9.2	3.8	3.97	0.8	●	●									
SOMT11T308	11	3.8	3.97	0.8	●	●									
SOMT130408	12.8	4.4	4.4	0.8	●	●									

●标准库存品 ○接受订货 ☆开发中, 近期供货

WCMX □□□□□□ (快速钻)

▲良好

△一般

	工件材质	P 中低硬度钢	△												
		P 高硬度钢、合金钢	▲	▲											
		M 不锈钢	▲	▲											
		K 铸铁	▲												
		N 有色金属													
		S 耐热合金													
		刀片基本尺寸				PVD涂层					CVD涂层			硬质合金	
D	d	S	R	PM8120	PM8125	PP8020	PP8030	KP1015	PC4115	PC4125	KC1015	KC1025	HI101		
WCMX030208R	5.56	2.55	2.38	0.8	●	●									
WCMX040208R	6.35	2.8	2.38	0.8	●	●									
WCMX050308R	7.94	3.4	3.18	0.8	●	●									
WCMX06T308R	9.52	4.4	3.97	0.8	●	●									
WCMX080412R	12.7	5.5	4.76	1.2	●	●									

●标准库存品 ○接受订货 ☆开发中, 近期供货

孔加工刀具 快速钻

钻孔刀片

SPGT □□□□□□ (快速钻)

▲良好

△一般

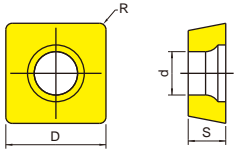
	工件材质				P 中低硬度钢		△															
					P 高硬度钢、合金钢		▲	▲														
					M 不锈钢		▲	▲														
					K 铸铁		▲															
					N 有色金属																	
					S 耐热合金																	
							刀片基本尺寸				PVD涂层					CVD涂层			硬质合金			
	D	d	S	R	PM8120	PM8125	PP8020	PP8030	KP1015	PC4115	PC4125	KC1015	KC1025	HI101								
SPGT050204	5	2.25	2.38	0.4	●	●																
SPGT060204	6	2.61	2.38	0.4	●	●																
SPGT07T308	7.94	2.85	3.97	0.8	●	●																
SPGT090408	9.8	4.05	4.3	0.8	●	●																
SPGT110408	11.5	4.45	4.8	0.8	●	●																
SPGT140512	14.3	5.75	5.2	1.2	●	●																
SPMG050204	5	2.25	2.38	0.4	●																	
SPMG060204	6	2.61	2.38	0.4	●																	
SPMG07T308	7.94	2.85	3.97	0.8	●																	
SPMG090408	9.8	4.05	4.3	0.8	●																	
SPMG110408	11.5	4.45	4.8	0.8	●																	
SPMG140512	14.3	5.75	5.2	1.2	●																	

●标准库存品 ○接受订货 ☆开发中, 近期供货

孔加工刀具 快速钻



镗刀

Boring Tool

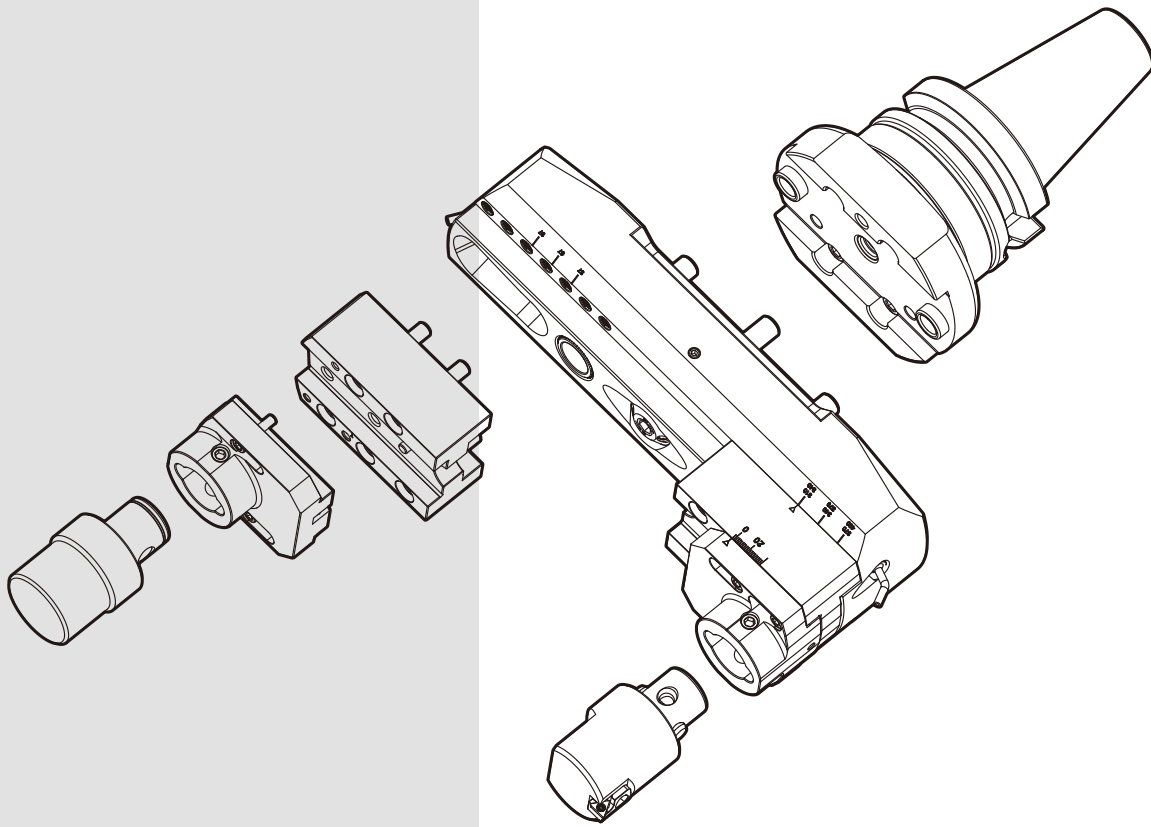

Boring Tool



CT-CK 模块式粗镗头(套件)

加工范围 $\Phi 20 - \Phi 232\text{mm}$

- 适用于各种粗镗重切削及断续切削场合，高效双刃镗孔，切削力均衡



改良的全排齿结构，刚性更有保障。

RB-DK 大孔径粗镗刀

加工范围 $\Phi 218 - \Phi 670\text{mm}$

- 适用于卧式镗铣床和龙门铣床
- 滑轨与刀柄的连接部位有防止串位机构，具备足够的安全性
- 模块化结构，更换相关组件后成为精镗刀
- 中心内藏冷却液管路，可直接冷却刀尖切削部位

1. 滑轨
2. 滑块
3. 刀夹
4. 刀柄
5. 冷却液喷管

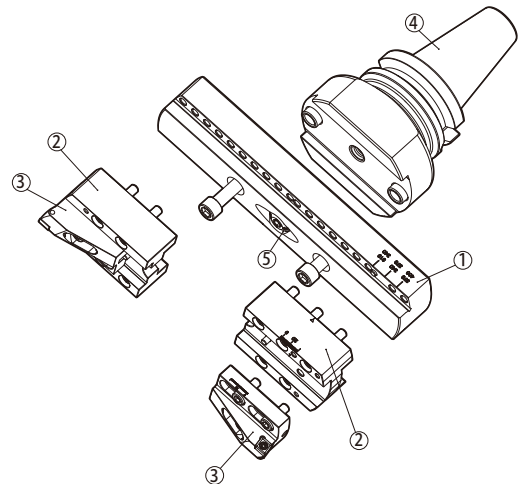

EW N-CKB 微调精镗头

加工范围 $\Phi 20 - \Phi 242\text{mm}$



FB-DK 大孔径精镗刀

加工范围 $\Phi 218 - \Phi 670\text{mm}$

- 模块化结构，更换相关组件后即成为大孔径粗镗头
- 中心内藏冷却液管路，可直接冷却刀尖切削部位

1. 滑轨
2. 滑块
3. 过度滑块
4. 精镗刀架
5. 平衡块
6. 刀柄
7. 冷却液喷管

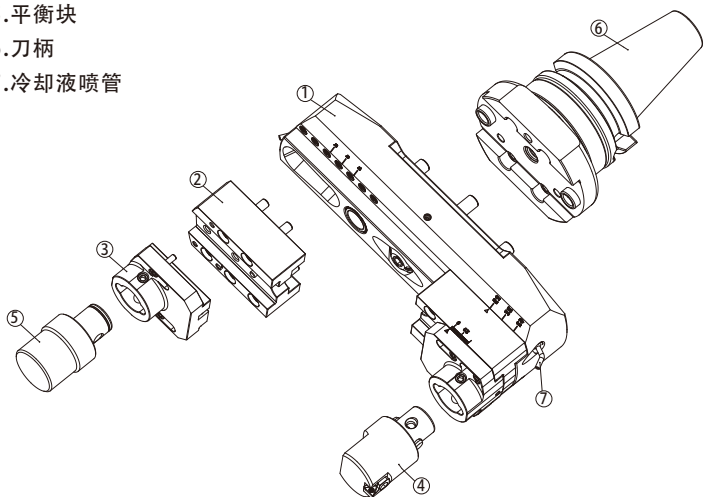

目录索引-1 按照刀具类别索引

■ CK 接口模块化镗孔刀具

BT40 粗镗刀-C 型	C 022
BT50 粗镗刀-C 型	C 023
BT40 粗镗刀-SA 型	C 024
BT50 粗镗刀-SA 型	C 025
BT30/BT40 精镗刀	C 026
BT50 精镗刀	C 027
CT-CK 粗镗刀头	C 028
CT-CK /CT-C /CT-MT 粗镗刀配件	C 029
CT-CK /CT-C /CT-MT 半精镗刀配件	C 029
EW N-CKB 微调精镗头	C 030
BT40/BT50-CK 型主轴柄	C 031
DAT40/DAT50-CK 型主轴柄	C 032
C 32/C 42 直柄-CK 接柄	C 033
CK 延长接柄	C 033
CK 缩径接柄	C 034
C 20/C 25/C 32-CKB 延长接柄	C 034
CK-CKB 缩径接柄	C 035
CK-CKB 转换接柄	C 035

目录索引-1 按照刀具类别索引

■ 模块化镗孔刀具

RB-DK 大孔径粗镗刀-轻载	C 036
RB-DK 大孔径粗镗刀-重载	C 038
FB-DK 大孔径精镗刀	C 041
加高滑块	C 043
套镗-粗镗刀-常规滑块	C 044
套镗-粗镗刀-加高滑块	C 045
扩展套镗-粗镗	C 046
套镗-精镗刀-常规滑块	C 047
套镗-精镗刀-加高滑块	C 047
扩展套镗-精镗	C 048
短型号主轴柄	C 049
长型号模块驳接主轴柄	C 050
更多驳接	C 051

■ 组合镗刀

NBJ16 微调精镗孔系统-套装	C 052
NBJ16 微调精镗孔系统-组件	C 053
NBH 2084 微调精镗孔系统-套装	C 054
NBH 2084 微调精镗孔系统-组件	C 055

■ 简易镗

CT-MT 莫氏柄粗镗刀	C 056
CT-C 直柄粗镗刀	C 057

■ 非标镗刀 C 058

■ 孔加工镗刀刀片 C 061

目录索引-1 按照刀具安装方式索引

📖 C 031
CK主轴柄

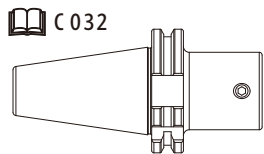
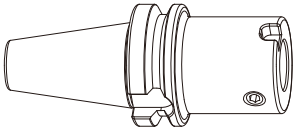

📖 D...
BT50-SLC 32-... E

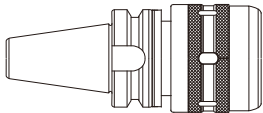

📖 C 033
直柄转CK接柄

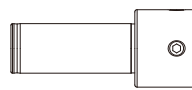

CK 延长接柄 📖 C 033

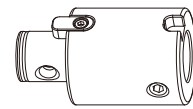

CK 缩径接柄 📖 C 034

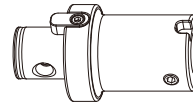

📖 C 053
NBH16主轴柄

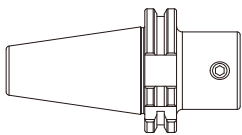
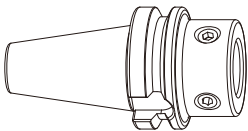

📖 C 054
NBH2084主轴柄

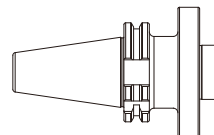
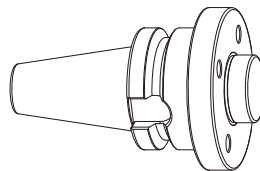

孔加工刀具
镗刀

📖 C 035

CK-CKB转接柄

📖 C 035

CK-CKB 缩径接柄

📖 C 030

EW N-CKB

📖 C 030

精 镗

📖 C 028

CT-CK系列

📖 C 029

粗 镗

📖 C 053

NBJ16

📖 C 053

精 镗

📖 C 055

NBH2084







📖 C 055

DK镗孔系统

📖 C 049

DK型主轴柄

📖 C 037 轻载
C 039 重载

-  (2件/套)
-  (2件/套)
-  (2件/套)
-  (2件/套)
-  (2件/套)
-  (2件/套)
-  (2件/套)

📖 C 037 轻载
C 039 重载

📖 C 037 轻载
C 039 重载

RB-DK

粗镗

FB-DK

精镗

(2件/套)

📖 C 042

(2件/套)

📖 C 042

📖 C 042

孔加工刀具
镗刀

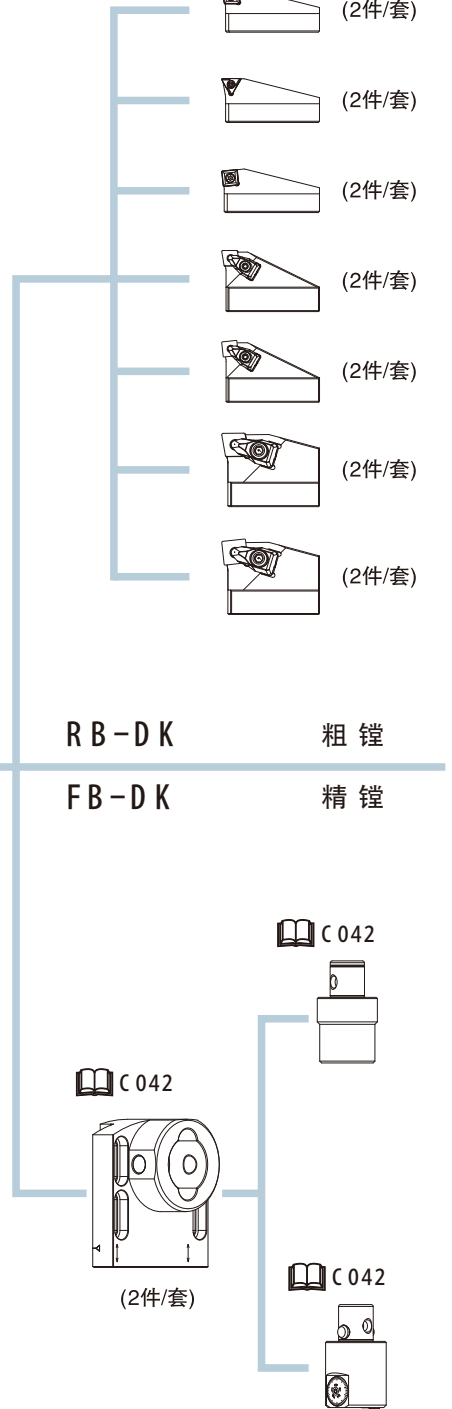
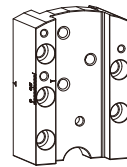
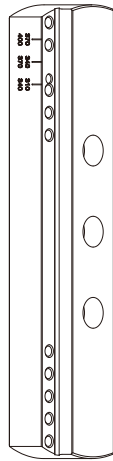
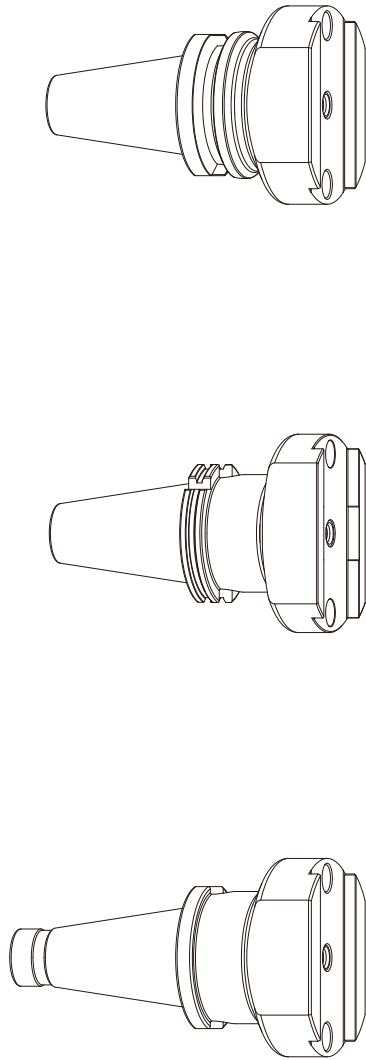

CK 接口模块化镗孔刀具

BT40 粗镗刀-C 型

Φ20-232 通孔、盲孔、台阶孔

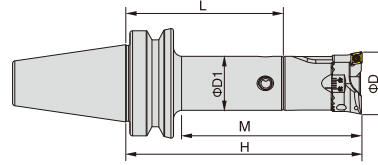

型号	镗孔范围 ΦD	有效深度 M	组合内容		CK NO.	尺寸 (mm)			重量 (Kg)
			主轴柄	粗镗头		H	L	ΦD1	
BT40-CK1-CT20C-95 -125	20-25	63	BT40-CK1-60 -90	CK1-CT2025C	CK1	95	60	19	0.96
		93				125	90		1.18
BT40-CK2-CT25C-100 -130 -160	25-30	68	BT40-CK2-60 -90 -120	CK2-CT2530C	CK2	100	60	24	1.15
		98				130	90		1.22
		128				160	120		1.31
BT40-CK2-CT29C-100 -130 -160	29-37	68	BT40-CK2-60 -90 -120	CK2-CT2937C	CK2	100	60	24	1.20
		98				130	90		1.28
		128				160	120		1.39
BT40-CK3-CT36C-105 -135 -165	36-46	73	BT40-CK3-60 -90 -120	CK3-CT3646C	CK3	105	60	31	1.33
		103				135	90		1.51
		133				165	120		1.68
BT40-CK4-CT45C-115 -155 -205	45-57	83	BT40-CK4-60 -100 -150	CK4-CT4557C	CK4	115	60	40	1.66
		123				155	100		2.04
		173				205	150		2.54
BT40-CK5-CT56C-120 -160 -210 -260	56-74	90	BT40-CK5-60 -100 -150 -200	CK5-CT5674C	CK5	120	60	48.5	2.06
		130				160	100		2.58
		178				210	150		3.30
		228				260	200		4.10
BT40-CK6-CT73C-125 -165 -215 -265	73-91	98	BT40-CK6-60 -100 -150 -200	CK6-CT7391C	CK6	125	60	63.5	2.79
		138				165	100		3.58
		188				215	150		4.60
		238				265	200		4.33
BT40-CK6-CT90C-130 -170 -220 -270	90-115	103	BT40-CK6-60 -100 -150 -200	CK6-CT90115C	CK6	130	60	63.5	3.58
		143				170	100		4.37
		193				220	150		5.39
		243				270	200		5.12
BT40-CK6-CT114C-140 -180 -230 -280	114-142	113	BT40-CK6-60 -100 -150 -200	CK6-CT114142C	CK6	140	60	63.5	4.30
		153				180	100		5.09
		203				230	150		6.11
		253				280	200		5.84
BT40-CK6-CT141C-140 -180 -230 -280	141-169	113	BT40-CK6-60 -100 -150 -200	CK6-CT141169C	CK6	140	60	63.5	5.49
		153				180	100		6.28
		203				230	150		7.30
		253				280	200		7.03
BT40-CK6-CT168C-145 -185 -235 -285	168-200	118	BT40-CK6-60 -100 -150 -200	CK6-CT165201C	CK6	145	60	63.5	6.41
		158				185	100		7.20
		208				235	150		8.22
		258				285	200		7.95
BT40-CK6-CT199C-145 -185 -235 -285	199-232	118	BT40-CK6-60 -100 -150 -200	CK6-CT165201C	CK6	145	60	63.5	6.41
		158				185	100		7.20
		208				235	150		8.22
		258				285	200		7.95
BT40-CK7-CT141C-170	141-169	143	BT40-CK7-90	CK7-CT141169C	CK7	170	90	83	7.19
BT40-CK7-CT168C-175	168-200	148	BT40-CK7-90	CK7-CT168200C	CK7	175	90	83	7.91
BT40-CK7-CT199C-175	199-232	148	BT40-CK7-90	CK7-CT199232C	CK7	180	90	83	8.63

孔加工刀具
镗刀

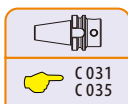

C 031
C 035

CK 接口模块化镗孔刀具

BT50 粗镗刀-C 型

Φ20-232 通孔、盲孔、台阶孔

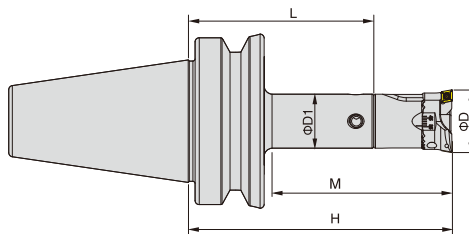

型号	镗孔范围 ΦD	有效深度 M	组合内容		CK NO.	尺寸(mm)			重量 (Kg)
			主轴柄	粗镗头		H	L	ΦD1	
BT50-CK1-CT20C-135	20-25	92	BT50-CK1-100	CK1-CT2025C	CK1	135	100	19	3.46
BT50-CK2-CT25C-140	25-30	97	BT50-CK2-100	CK2-CT2530C	CK2	140	100	24	3.78
BT50-CK2-CT29C-140	29-37	97	BT50-CK2-100	CK2-CT2937C	CK2	140	100	24	3.94
BT50-CK3-CT36C-145	36-46	102	BT50-CK3-100	CK3-CT3646C	CK3	145	100	31	4.13
-195		152	-150			195	150		4.41
BT50-CK4-CT45C-155	45-57	112	BT50-CK4-100	CK4-CT4557C	CK4	155	100	40	4.56
-205		162	-150			205	150		5.08
BT50-CK5-CT56C-160	56-74	117	BT50-CK5-100	CK5-CT5674C	CK5	160	100	48.5	4.96
-210		167	-150			210	150		5.67
-260		217	200			260	200		6.40
BT50-CK6-CT73C-165	73-91	122	BT50-CK6-100	CK6-CT7391C	CK6	165	100	63.5	5.87
-215		172	-150			215	150		7.11
-265		222	-200			265	200		7.53
-315		272	-250			315	250		8.13
BT50-CK6-CT90C-170		90-115	127			BT50-CK6-100	CK6-CT90115C		CK6
-220	177		-150	220	150	7.90			
-270	227		-200	270	200	8.32			
-320	277		-250	320	250	8.92			
BT50-CK6-CT114C-180	114-142	137	BT50-CK6-100	CK6-CT114142C	CK6	180	100	63.5	7.38
-230		187	-150			230	150		8.62
-280		237	-200			280	200		9.04
-330		287	-250			330	250		9.64
BT50-CK6-CT141C-180	141-169	137	BT50-CK6-100	CK6-CT141169C	CK6	180	100	63.5	8.57
-230		187	-150			230	150		9.81
-280		237	-200			280	200		10.23
-330		287	-250			330	250		10.83
BT50-CK6-CT168C-185	168-200	142	BT50-CK6-100	CK6-CT168200C	CK6	185	100	63.5	9.49
-235		192	-150			235	150		10.73
-285		242	-200			285	200		11.15
-335		292	-250			335	250		11.75
BT50-CK6-CT199C-185		199-232	142			BT50-CK6-100	CK6-CT199232C		CK6
-235	192		-150	235	150	10.73			
-285	242		-200	285	200	11.15			
-335	292		-250	335	250	11.75			
BT50-CK7-CT141C-180	141-169	137	BT50-CK7-100	CK7-CT141169C	CK7	180	100	83	9.87
-230		187	-150			230	150		11.89
-280		237	-200			280	200		13.41
-330		287	-250			330	250		14.78
BT50-CK7-CT168C-185	168-200	142	BT50-CK7-100	CK7-CT168200C	CK7	185	100	83	10.59
-235		192	-150			235	150		12.61
-285		242	-200			285	200		14.13
-335		292	-250			335	250		15.50
BT50-CK7-CT199C-185		199-232	142			BT50-CK7-100	CK7-CT199232C		CK7
-235	192		-150	235	150	12.61			
-285	242		-200	285	200	14.13			
-335	292		-250	335	250	15.50			

孔加工刀具 镗刀

CK接口模块化镗孔刀具

BT40 粗镗刀-SA型

Φ31-232 通孔

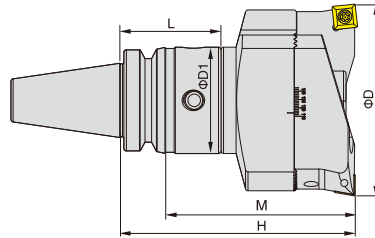
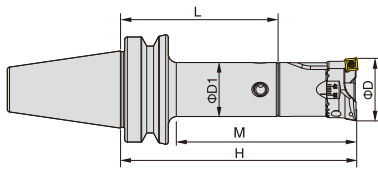

型号	镗孔范围 ΦD	有效深度 M	组合内容		CK NO.	尺寸(mm)			重量 (Kg)
			主轴柄	粗镗头		H	L	ΦD1	
BT40-CK2-CT31SA-100	31-39	68	BT40-CK2-60	CK2-CT3139SA	CK2	100	60	24	1.20
-130		98	-90			130	90		1.28
-160		128	-120			160	120		1.39
BT40-CK3-CT38SA-105	38-48	73	BT40-CK3-60	CK3-CT3848SA	CK3	105	60	31	1.33
-135		103	-90			135	90		1.51
-165		133	-120			165	120		1.68
BT40-CK4-CT45SA-115	45-57	83	BT40-CK4-60	CK4-CT4557SA	CK4	115	60	40	1.66
-155		123	-100			155	100		2.04
-205		173	-150			205	150		2.54
BT40-CK5-CT56SA-120	56-74	90	BT40-CK5-60	CK5-CT-5674SA	CK5	120	60	48.5	2.06
-160		130	-100			160	100		2.58
-210		178	-150			210	150		3.30
-260		228	-200			260	200		4.10
BT40-CK6-CT73SA-125	73-91	98	BT40-CK6-60	CK6-CT7391SA	CK6	125	60	63.5	2.79
-165		138	-100			165	100		3.58
-215		188	-150			215	150		4.60
-265		238	-200			265	200		4.33
BT40-CK6-CT90SA-130	90-115	103	BT40-CK6-60	CK6-CT90115SA	CK6	130	60	63.5	3.62
-170		143	-100			170	100		4.41
-220		193	-150			220	150		5.43
-270		243	-200			270	200		5.16
BT40-CK6-CT114SA-140	114-142	113	BT40-CK6-60	CK6-CT114142SA	CK6	140	60	63.5	4.31
-180		153	-100			180	100		5.10
-230		203	-150			230	150		6.12
-280		253	-200			280	200		5.85
BT40-CK6-CT141SA-140	141-169	113	BT40-CK6-60	CK6-CT141169SA	CK6	140	60	63.5	5.50
-180		153	-100			180	100		6.29
-230		203	-150			230	150		7.31
-280		253	-200			280	200		7.04
BT40-CK6-CT168SA-145	168-200	118	BT40-CK6-60	CK6-CT165201SA	CK6	145	60	63.5	6.45
-185		158	-100			185	100		7.24
-235		208	-150			235	150		8.26
-285		258	-200			285	200		7.99
BT40-CK6-CT199SA-145	199-232	118	BT40-CK6-60	CK6-CT165201SA	CK6	145	60	63.5	6.45
-185		158	-100			185	100		7.24
-235		208	-150			235	150		8.26
-285		258	-200			285	200		7.99
BT40-CK7-CT141SA-170	141-169	143	BT40-CK7-90	CK7-CT141169SA	CK7	170	90	83	7.22
BT40-CK7-CT168SA-175	168-200	148	BT40-CK7-90	CK7-CT168200SA	CK7	175	90	83	7.94
BT40-CK7-CT199SA-175	199-232	148	BT40-CK7-90	CK7-CT199232SA	CK7	180	90	83	8.66

孔加工刀具
镗刀

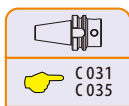

CK接口模块化镗孔刀具

BT50 粗镗刀-SA型

Φ31-232 通孔

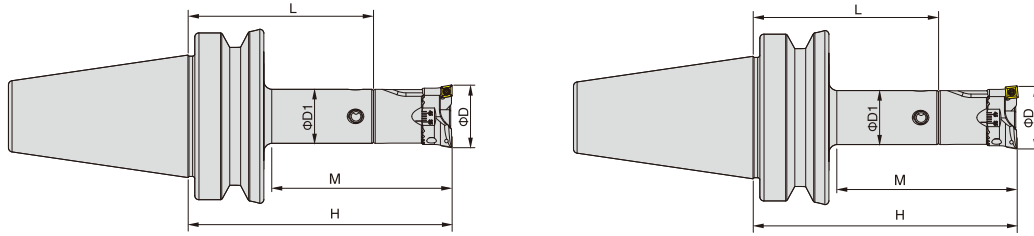

型号	镗孔范围 ΦD	有效深度 M	组合内容		CK NO.	尺寸(mm)			重量 (Kg)		
			主轴柄	粗镗头		H	L	ΦD1			
BT50-CK2-CT31SA-140	31-39	97	BT50-CK2-100	CK2-CT3139SA	CK2	140	100	24	3.94		
BT50-CK3-CT38SA-145	38-48	102	BT50-CK3-100	CK3-CT3848SA	CK3	145	100	31	4.13		
-195		152				-150			195	150	4.41
BT50-CK4-CT45SA-155	45-57	112	BT50-CK4-100	CK4-CT4557SA	CK4	155	100	40	4.56		
-205		162				-150			205	150	5.08
BT50-CK5-CT56SA-160	56-74	117	BT50-CK5-100	CK5-CT5674SA	CK5	160	100	48.5	4.96		
-210		167				-150			210	150	5.67
-260		217				200			260	200	6.40
BT50-CK6-CT73SA-165	73-91	122	BT50-CK6-100	CK6-CT7391SA	CK6	165	100	63.5	5.87		
-215		172				-150			215	150	7.11
-265		222				-200			265	200	7.53
-315		272				-250			315	250	8.13
BT50-CK6-CT90SA-170	90-115	127	BT50-CK6-100	CK6-CT90115SA	CK6	170	100	63.5	6.70		
-220		177				-150			220	150	7.94
-270		227				-200			270	200	8.36
-320		277				-250			320	250	8.96
BT50-CK6-CT114SA-180	114-142	137	BT50-CK6-100	CK6-CT114142SA	CK6	180	100	63.5	7.39		
-230		187				-150			230	150	8.63
-280		237				-200			280	200	9.05
-330		287				-250			330	250	9.65
BT50-CK6-CT141SA-180	141-169	137	BT50-CK6-100	CK6-CT141169SA	CK6	180	100	63.5	8.58		
-230		187				-150			230	150	9.82
-280		237				-200			280	200	10.24
-330		287				-250			330	250	10.84
BT50-CK6-CT168SA-185	168-200	142	BT50-CK6-100	CK6-CT168200SA	CK6	185	100	63.5	9.53		
-235		192				-150			235	150	10.77
-285		242				-200			285	200	11.19
-335		292				-250			335	250	11.79
BT50-CK6-CT199SA-185	199-232	142	BT50-CK6-100	CK6-CT199232SA	CK6	185	100	63.5	9.53		
-235		192				-150			235	150	10.77
-285		242				-200			285	200	11.19
-335		292				-250			335	250	11.79
BT50-CK7-CT141SA-180	141-169	137	BT50-CK7-100	CK7-CT141169SA	CK7	180	100	83	9.90		
-230		187				-150			230	150	11.92
-280		237				-200			280	200	13.44
-330		287				-250			330	250	14.81
BT50-CK7-CT168SA-185	168-200	142	BT50-CK7-100	CK7-CT168200SA	CK7	185	100	83	10.62		
-235		192				-150			235	150	12.64
-285		242				-200			285	200	14.16
-335		292				-250			335	250	15.53
BT50-CK7-CT199SA-185	199-232	142	BT50-CK7-100	CK7-CT199232SA	CK7	185	100	83	10.62		
-235		192				-150			235	150	12.64
-285		242				-200			285	200	14.16
-335		292				-250			335	250	15.53

孔加工刀具
镗刀

CK接口模块化镗孔刀具

BT30/BT40 精镗刀

Φ20-153 通孔、盲孔、台阶孔

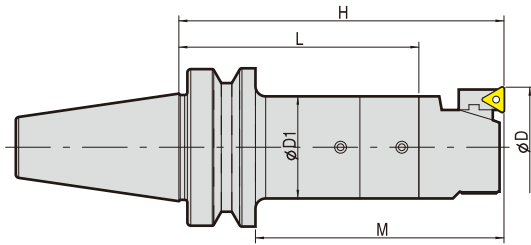

Fig.2

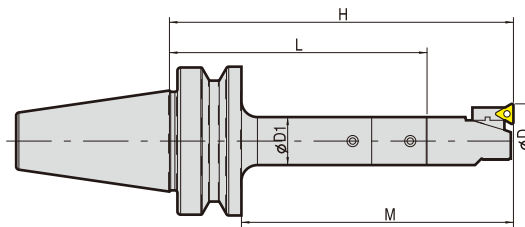
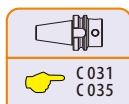

Fig.1

型号	镗孔范围 φ D	有效深度 M	组合内容			Fig.	CK NO.	尺寸			重量 (kg)
			主轴柄	CK-CKB转换接柄	精镗头			H	L	φ D1	
BT30-CK1-EWN20-112 -122	20-26	87	BT30-CK1-60	CK1-CKB1-20L -30L	EWN20-36CKB1	2	1	112	80	19	0.68
		97						122	90		0.56
BT30-CK2-EWN25-125 -140	25-33	100	-CK2-60	CK2-CKB2-30L -45L	EWN25-47CKB2	2	2	125	90	24	0.78
		115						140	105		0.61
BT30-CK3-EWN32-130 -145	32-42	105	-CK3-60	CK3-CKB3-30L -45L	EWN32-60CKB3	2	3	130	90	31	0.88
		120						145	105		0.78
BT30-CK4-EWN41-152 -167	41-54	127	-CK4-60	CK4-CKB4-45L -60L	EWN41-74CKB4	2	4	152	105	39	1.28
		142						167	120		1.18
BT30-CK5-EWN53-177 -207	53-70	152	-CK5-60	CK5-CKB5-60L -90L	EWN53-95CKB5	2	5	177	120	50	1.83
		182						207	150		1.73
BT40-CK1-EWN20-115 -152	20-26	82	BT40-CK1-60 -90	CK1-CKB1-20L -30L	EWN20-36CKB1	2	1	115	60	19	1.25
		122				152		90	1.28		
BT40-CK2-EWN25-125 -170 -200	25-33	95	BT40-CK2-60 -90 -120	CK2-CKB2-30L -45L -45L	EWN25-47CKB2	2	2	125	90	24	1.3
		140				170		135	1.38		
		170				200		165	1.49		
BT40-CK3-EWN32-130 -175 -205	32-42	100	BT40-CK3-60 -90 -120	CK3-CKB3-30L -45L -45L	EWN32-60CKB3	2	3	130	90	31	1.47
		145				175		135	1.65		
		175				205		165	1.82		
BT40-CK4-EWN41-152 -207 -257	41-54	122	BT40-CK4-60 -100 -150	CK4-CKB4-45L -60L -60L	EWN41-74CKB4	2	4	152	105	39	1.87
		177				207		160	2.25		
		227				257		210	2.75		
BT40-CK5-EWN53-177 -217 -267 -317	53-70	147	BT40-CK5-60 -100 -150 -200	CK5-CKB5-60L	EWN53-95CKB5	2	5	177	120	50	3.42
		187				217		160	3.94		
		237				267		210	4.66		
		287				317		260	4.46		
BT40-CK6-EWN68-191 -271 -321 -371	68-100	161	BT40-CK6-60 -100 -150 -200	CK6-CKB6-60L -100L -100L -100L	EWN68-150CKB6	2	6	191	120	64	4.57
		241						271	200		4.96
		291						321	250		6.88
		341						371	300		7.21
BT40-CK6-EWN100-191 -271 -321 -371	100-153	161	BT40-CK6-60 -100 -150 -200	CK6-CKB6-60L -100L -100L -100L	EWN100-203CKB6	2	6	191	120	64	4.97
		241						271	200		5.86
		291						321	250		6.02
		341						371	300		6.71

◇以上镗孔范围为默认配置，如需扩展镗孔尺寸范围，可另行选配刀夹：ENH*2-TP/TC、ENH*3-TP/TC C030



CK接口模块化镗孔刀具

BT50 精镗刀

Φ20-217 通孔、盲孔、台阶孔

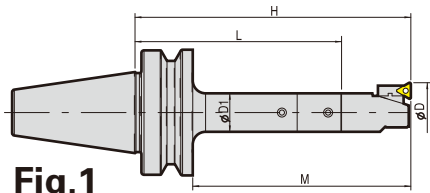

Fig.1

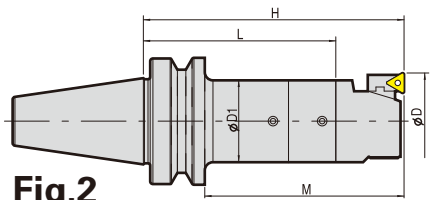

Fig.2

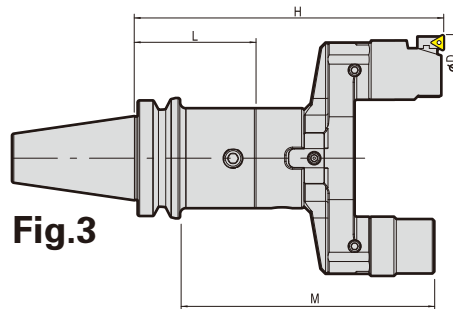

Fig.3



型号	镗孔范围 φ D	有效深度 M	组合内容			Fig.	CK NO.	尺寸			重量 (kg)
			主轴柄	CK-CKB转换柄	精镗头			H	L	φ D1	
BT50-CK1-EWN20-152 -162	20-26	112	BT50-CK1-100	CK1-CKB1-20L -30L	EWN20-36CKB1	1	1	152	120	19	4.25
		122						162	130		4.95
BT50-CK2-EWN25-165 -180	25-33	125	BT50-CK2-100	CK2-CKB2-30L -45L	EWN25-47CKB2	1	2	165	130	24	4.34
		140						180	145		5.34
BT50-CK3-EWN32-170 -235	32-42	130	BT50-CK3-100	CK3-CKB3-30L -45L	EWN32-60CKB3	1	3	170	130	31	5.17
		190				235		190	5.45		
BT50-CK4-EWN41-192 -257	41-54	152	BT50-CK4-100	CK4-CKB4-45L -60L	EWN41-74CKB4	2	4	192	145	39	5.76
		217				257		210	6.19		
BT50-CK5-EWN53-217 -267 -317	53-70	177	BT50-CK5-100	CK5-CKB5-60L	EWN53-95CKB5	2	5	217	160	50	6.22
		227				267		210	6.93		
		277				317		260	7.66		
BT50-CK6-EWN68-231 -321 -371 -421	68-100	191	BT50-CK6-100	CK6-CKB6-60L -100L -100L -100L	EWN68-150CKB6	2	6	231	160	64	7.55
		281				321		250	8.79		
		331				371		300	9.21		
		381				421		350	9.81		
BT50-CK6-EWN100-231 -321 -371 -421	100-153	221	BT50-CK6-100	CK6-CKB6-60L -100L -100L -100L	EWN100-203CKB6	2	6	231	160	64	7.55
		311				321		250	8.79		
		361				371		300	9.21		
		411				421		350	9.81		
BT50-CK7-EWN100-287 -337 -387 -437	100-153	277	BT50-CK7-100	CK7-CKB6-100L CK7-CKB7-100L	EWN100-203CKB6 EWN100-203CKB7	2	7	287	200	90	11.44
		327						337	250		13.46
		377						387	300		14.98
		427						437	350		16.35
BT50-CK7-EWN200-212 -262 -312 -362	200-217	202	BT50-CK7-100	—	EWN200-242CK7	3	7	212	100	90	9.44
		252						262	150		11.46
		302						312	200		12.98
		352						362	250		14.35
BT50-CK7-EWN200-462		452	-250	CK7-7-100L				462	350		19.61

◇以上镗孔范围为默认配置，如需扩展镗孔尺寸范围，可另行选配刀夹：ENH*-2-TP/TC、ENH*-3-TP/TC C 030

孔加工刀具 镗刀

CK 接口模块化镗孔刀具

CT-CK 粗镗刀头

Φ20-232 通孔、盲孔、台阶孔

改良的全排齿结构，刚性更有保障。

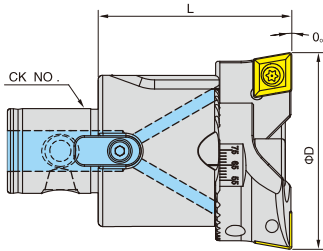
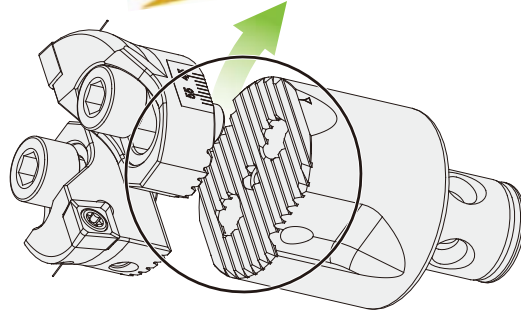

盲孔用 C型

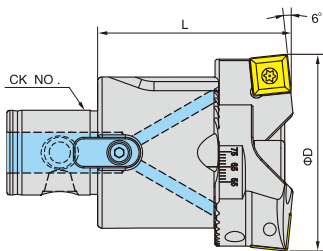

通孔用 SA型

订货型号 (套件)	镗孔范围ΦD	尺寸(mm)		适用刀片	重量 (Kg)
		CK NO.	L		
CK1-CT2025C	20-25	CK1	35	CCMT060204	0.06
CK2-CT2530C	25-30	CK2	40	CCMT060204	0.09
CK2-CT2937C	29-37	CK2	40	CCMT060204	0.13
CK3-CT3646C	36-46	CK3	45	CCMT060204	0.27
CK4-CT4557C	45-57	CK4	55	CCMT09T308	0.51
CK5-CT5674C	56-74	CK5	60	CCMT120408	0.80
CK6-CT7391C	73-91	CK6	65	CCMT120408	1.42
CK6-CT90115C	90-115	CK6	70	CCMT120408	2.21
CK6-CT114142C	114-142	CK6	80	CCMT120408	2.93
CK6-CT141169C	141-169	CK6	80	CCMT120408	4.12
CK6-CT168200C	168-200	CK6	85	CCMT120408	5.04
CK6-CT199232C	199-232	CK6	85	CCMT120408	5.2
CK7-CT141169C	141-169	CK7	80	CCMT120408	4.53
CK7-CT168200C	168-200	CK7	85	CCMT120408	5.25
CK7-CT199232C	199-232	CK7	85	CCMT120408	5.5
CK2-CT3139SA	31-39	CK2	40	SCMT09T308	0.13
CK3-CT3848SA	38-48	CK3	45	SCMT09T308	0.27
CK4-CT4557SA	45-57	CK4	55	SCMT09T308	0.51
CK5-CT5674SA	56-74	CK5	60	SCMT120408	0.80
CK6-CT7391SA	73-91	CK6	65	SCMT120408	1.42
CK6-CT90115SA	90-115	CK6	70	SCMT120408	2.25
CK6-CT114142SA	114-142	CK6	80	SCMT120408	2.94
CK6-CT141169SA	141-169	CK6	80	SCMT120408	4.13
CK6-CT168200SA	168-200	CK6	85	SCMT120408	5.08
CK6-CT199232SA	199-232	CK6	85	SCMT120408	5.24
CK7-CT141169SA	141-169	CK7	80	SCMT120408	4.56
CK7-CT168200SA	168-200	CK7	85	SCMT120408	5.28
CK7-CT199232SA	199-232	CK7	85	SCMT120408	5.5

◇ 刀片需单独订购。

◇ 订货示例：粗镗头1套 型号CK5-CT5674C或CK5-CT5674SA

◇ 型号编制说明：**CK5** - **CT5674** **C**

CK 接口
 镗孔范围
 C 型刀片

孔加工刀具 镗刀

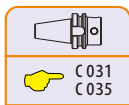

CK 接口模块化镗孔刀具

CT-CK / CT-C / CT-MT 粗镗刀配件

镗孔范围	刀夹订货型号	适用刀片	配件订货型号							
			刀片螺钉	调节螺钉	锁固螺钉-1	锁固螺钉-2	垫圈	键	键螺钉	扳手
20-25	CT20C	CCMT060204	R 25060G	FM04005	CTS20-M4	-----	DWC-M4	-----	-----	T8F/S2L/S4L
25-30	CT25C	CCMT060204	R 25060G	FM04005	CTS25-M5	-----	DWC-M5	CKSP2	BM02005	T8F/S2L/S4L
29-37	CT29C	CCMT060204	R 25060G	FM04006	CTS25-M5	-----	DWC-M5	CKSP2	BM02005	T8F/S2L/S4L
	CT31SA	CCMT09T308	R 40100J	FM04006	CTS25-M5	-----	DWC-M5	CKSP2	BM02005	T8F/S2L/S4L
36-46	CT36C	CCMT09T308	R 40100J	FM04008	CTS36-M6	-----	DWC-M6	CKSP3	BM02508	T8F/S2L/S5L
	CT38SA	CCMT09T308	R 40100J	FM04008	CTS36-M6	-----	DWC-M6	CKSP3	BM02508	T8F/S2L/S5L
45-57	CT45C	CCMT09T308	R 40100J	FM05010	CTS45-M8	-----	DWC-M8	CKSP4	BM03010	T15F/S2.5L/S6L
	CT45SA	SCMT09T308	R 40100J	FM05010	CTS45-M8	-----	DWC-M10	CKSP4	BM03010	T15F/S2.5L/S6L
56-74	CT56C	CCMT120408	R 50120J	FM06012	CTS56-M10	-----	DWC-M10	CKSP5	BM04012	T15F/S3L/S8L
	CT56SA	SCMT120408	R 50120J	FM06012	CTS56-M10	-----	DWC-M10	CKSP5	BM04012	T15F/S3L/S8L
73-91	CT73C	CCMT120408	R 50120J	FM06012	CTS73-M10	BM10040	DWC-M10	CKSP6	BM05016	T20F/S3L/S8L
	CT73SA	SCMT120408	R 50120J	FM06012	CTS73-M10	BM10040	DWC-M10	CKSP6	BM05016	T20F/S3L/S8L
90-115	CT90C	CCMT120408	R 50120J	FM08016	CTS90-M12	BM12035	DWC-M12	CKSP6	BM05016	T20F/S4L/S10L
	CT90SA	SCMT120408	R 50120J	FM08016	CTS90-M12	BM12035	DWC-M12	CKSP6	BM05016	T20F/S4L/S10L
114-142	CT114C	CCMT120408	R 50120J	FM08020	CTS90-M12	BM12045	DWC-M12	CKSP6	BM05016	T20F/S4L/S10L
	CT114SA	SCMT120408	R 50120J	FM08020	CTS90-M12	BM12045	DWC-M12	CKSP6	BM05016	T20F/S4L/S10L
141-169	CT114C	CCMT120408	R 50120J	FM08020	CTS90-M12	BM12045	DWC-M12	CKSP6/7	BM06020※	T20F/S4L/S10L
	CT114SA	SCMT120408	R 50120J	FM08020	CTS90-M12	BM12045	DWC-M12	CKSP6/7	BM06020※	T20F/S4L/S10L
168-200	CT168C	CCMT120408	R 50120J	FM08020	CTS90-M12	BM12045	DWC-M12	CKSP6/7	BM06020※	T20F/S4L/S10L
	CT168SA	SCMT120408	R 50120J	FM08020	CTS90-M12	BM12045	DWC-M12	CKSP6/7	BM06020※	T20F/S4L/S10L
199-232	CT199C	CCMT120408	R 50120J	FM08020	CTS90-M12	BM12045	DWC-M12	CKSP6/7	BM06020※	T20F/S4L/S10L
	CT199SA	SCMT120408	R 50120J	FM08020	CTS90-M12	BM12045	DWC-M12	CKSP6/7	BM06020※	T20F/S4L/S10L

- ◇小刀夹只能成对订购，不售单只。
- ◇每个刀夹包含表格中所列举的配件。
- ◇刀片需单独订购。

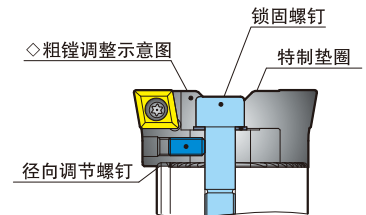
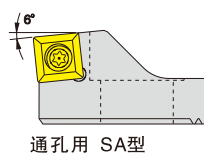
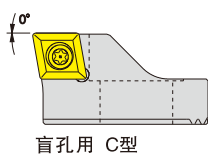

CK 接口模块化镗孔刀具

CT-CK / CT-C / CT-MT 半精镗刀配件

镗孔范围	刀夹订货型号	适用刀片	配件订货型号			
			刀片螺钉	保护盖	锁固螺钉-3	扳手
20-25	CT20T	TP□□0802□□L	R 20050J	PC20	BM04016	T6F
25-30	CT25T	TP□□0802□□L	R 20050J	PC25	BM05016	T6F
29-37	CT29T	TP□□0902□□L	R 25060G	PC29	BM05016	T6F
36-46	CT36T	TP□□0902□□L	R 25060G	PC36	BM06020	T6F
45-57	CT45T	TP□□1103□□L	R 30070E	PC45	BM08025	T6F
56-74	CT56T	TP□□1103□□L	R 30070E	PC56	BM10025	T8F
73-91	CT73T	TP□□1103□□L	R 30070E	PC73	BM10030	T8F
90-115	CT90T	TP□□1103□□L	R 30070E	PC90	BM12025	T8F
114-142	CT114T	TP□□1103□□L	R 30070E	PC114	BM12030	T8F
141-169	CT114T	TP□□1103□□L	R 30070E	PC114	BM12030	T8F
168-200	CT168T	TP□□1103□□L	R 30070E	PC168	BM12030	T8F
199-232	CT199T	TP□□1103□□L	R 30070E	PC199	BM12030	T8F

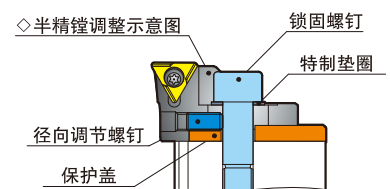
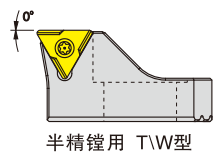

◇与粗镗刀共通配件不再列举。

CK接口模块化镗孔刀具

EWN-CKB 微调精镗头

Φ20-242 通孔、盲孔、台阶孔

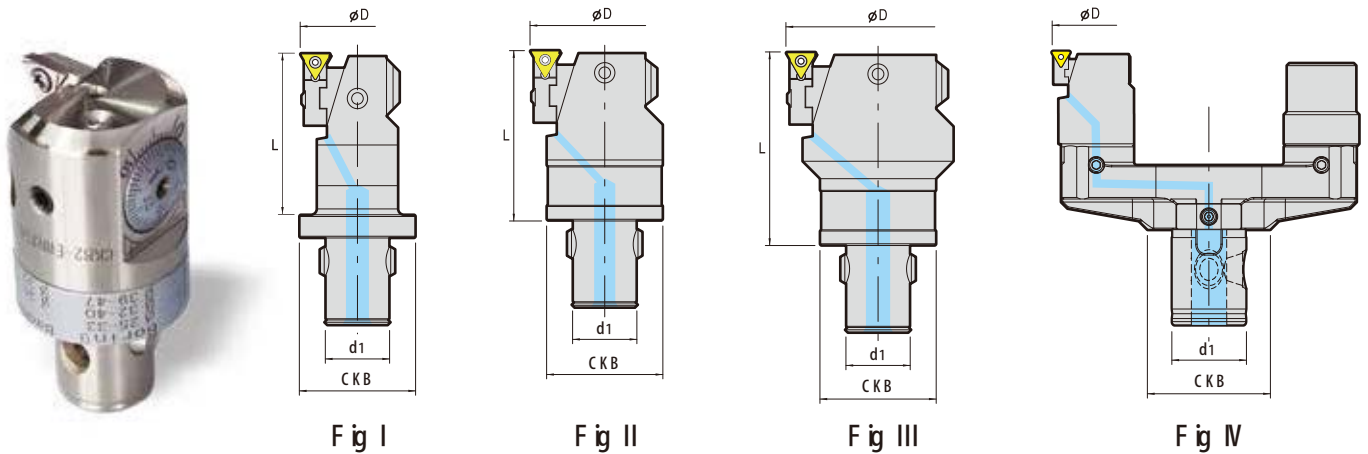

订货型号 (套件)	CKB NO.	Fig	配用小刀夹		刀夹 螺钉	尺寸 (mm)				重量 (Kg)	刀片/螺钉
			TP	TC		镗孔范围 (ΦD)	d1	CKB	L		
EWN20-36CKB1-TP	CKB1	Fig I	ENH1-1-TP	---	MS 03006	20-26	11	19	32.5	0.07	
			ENH1-2-TP	---		25-31					
			ENH1-3-TP	---		30-36					
EWN25-47CKB2-TP	CKB2	Fig II	ENH2-1-TP	---	MS 03008	25-33	14	24	35.5	0.12	TPGT0802□□□□
			ENH2-2-TP	---		32-40					
			ENH2-3-TP	---		39-47					
EWN32-60CKB3-TP	CKB3	Fig II	ENH3-1-TP	---	MS 04010	32-42	18	31	40	0.21	R 22050J-T7 M 2.2x5
			ENH3-2-TP	---		41-51					
			ENH3-3-TP	---		50-60					
EWN41-74CKB4-TP/TC	CKB4	Fig II	ENH4-1-TP	ENH4-1-TC	MS 05012	41-54	22	39	47	0.4	TC□□1102□□
			ENH4-2-TP	ENH4-2-TC		53-66					
			ENH4-3-TP	ENH4-3-TC		61-74					
EWN53-95CKB5-TP/TC	CKB5	Fig II	ENH5-1-TP	ENH5-1-TC	MS 05012	53-70	28	49	57	1.1	R 25060G + -T8 M 2.5x6
			ENH5-2-TP	ENH5-2-TC		68-85					
			ENH5-3-TP	ENH5-3-TC		78-95					
EWN68-150CKB6-TP/TC	CKB6	Fig III	ENH6-1-TP	ENH6-1-TC	MS 08020	68-100	36	63	71	1.74	TP□□1103□□
			ENH6-2-TP	ENH6-2-TC		93-125					
			ENH6-3-TP	ENH6-3-TC		125-150					
EWN100-203CKB6-TP/TC	CKB6	Fig III	ENH6-1-TP	ENH6-1-TC	MS 08020	100-153	36	63	71	2.46	TP□□1103□□
			ENH6-2-TP	ENH6-2-TC		126-178					
			ENH6-3-TP	ENH6-3-TC		150-203					
EWN200-242CK7-TP/TC	CK7	Fig IV	ENH5-1-TP	ENH5-1-TC	MS 05012	200-217	42	83	112	4.1	R 25060G + -T8 M 2.5x6
			ENH5-2-TP	ENH5-2-TC		212-229					
			ENH5-3-TP	ENH5-3-TC		225-242					

◇默认配置:

EWN-CKB 微调精镗头配置的刀夹, 默认为ENH*-1-TP, CKB4 (含) 以上可选ENH*-1-TC

◇增程扩展配置:

根据所需的镗孔尺寸范围, 可另行选配ENH*-2-TP/TC、ENH*-3-TP/TC

◇订货型号示例:

- 1.EWN41-74CKB4-TP
- 2.EWN41-74CKB4-TC



CK 接口模块化镗孔刀具

BT40/BT50-CK型主轴柄



孔加工刀具
镗刀

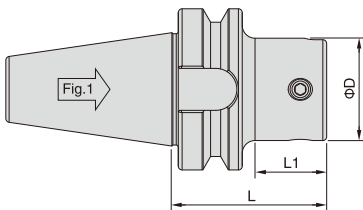
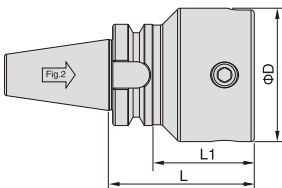

订货型号	尺寸(mm)				Fig.	螺钉	重量 (Kg)
	CK NO.	L	L1	ΦD			
BT40-CK1-60	1	60	28	19	1	CKS1	1.06
		90	58		1.09		
-CK2-60	2	60	28	24	1	CKS2	1.07
		90	58		1.15		
		120	88		1.26		
-CK3-60	3	60	28	31	1	CKS3	1.06
		90	58		1.24		
		120	88		1.41		
-CK4-60	4	60	28	40	1	CKS4	1.15
		100	68		1.53		
		150	118		2.03		
-CK5-60	5	60	30	48.5	1	CKS5	1.26
		100	68		1.78		
		150	118		2.50		
		200	168		3.30		
-CK6-60	6	60	33	63.5	2	CKS6	1.37
		100	73		2.16		
		150	123		3.18		
		200	173		2.91		
-CK7-90	7	90	63	83	2	CKS7	2.66
BT50-CK1-100	1	100	57	19	1	CKS1	3.76
-CK2-100	2	100	57	24	1	CKS2	3.81
-CK3-100	3	100	57	31	1	CKS3	3.86
		150	107		4.14		
-CK4-100	4	100	57	40	1	CKS4	4.05
		150	107		4.57		
-CK5-100	5	100	57	48.5	1	CKS5	4.16
		150	107		4.87		
		200	157		5.60		
-CK6-100	6	100	57	63.5	1	CKS6	4.45
		150	107		5.69		
		200	157		6.11		
		250	207		6.71		
-CK7-100	7	100	57	83	1	CKS7	5.34
		150	107		7.36		
		200	160		8.88		
		250	210		10.25		

CK 接口模块化镗孔刀具

DAT40/DAT50-CK型主轴柄

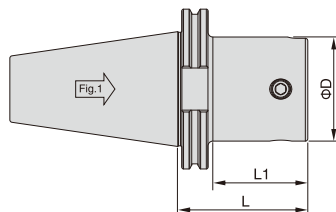
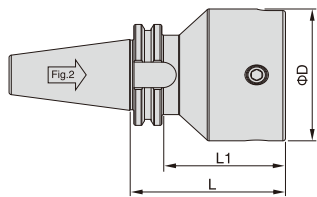

订货型号	尺寸(mm)				Fig.	螺钉	重量(Kg)
	CK NO.	L	L1	ΦD			
DAT40-CK1-60	1	60	36	19	1	CKS1	0.9
-90		90	66		0.93		
-CK2-60	2	60	36	24	1	CKS2	0.91
-90		90	66		0.99		
-120		120	96		1.1		
-CK3-60	3	60	36	31	1	CKS3	0.9
-90		90	66		1.08		
-120		120	96		1.25		
-CK4-60	4	60	36	40	1	CKS4	0.99
-100		100	66		1.37		
-150		150	96		1.87		
-CK5-60	5	60	38	48.5	1	CKS5	1.1
-100		100	78		1.62		
-CK6-60	6	60	40	63.5	2	CKS6	1.21
-100		100	80		2.0		
-CK7-90	7	90	70	83	2	CKS7	2.5
DAT50-CK1-100	1	100	76.2	19	1	CKS1	2.78
-CK2-100	2	100	76.1	24	1	CKS2	2.83
-CK3-100	3	100	76.1	31	1	CKS3	2.88
-150		150	126.1		3.16		
-CK4-100	4	100	75.9	40	1	CKS4	3.07
-150		150	125.9		3.59		
-CK5-100	5	100	76	48.5	1	CKS5	3.18
-150		150	126		3.89		
-200		200	176		4.62		
-CK6-100	6	100	76	63.5	1	CKS6	3.47
-150		150	126		4.71		
-200		200	176		5.13		
-250		250	226		5.73		
-CK7-100	7	100	81	83	1	CKS7	4.36
-150		150	131		6.38		
-200		200	181		7.90		
-250		250	231		9.27		

CK 接口模块化镗孔刀具

C32/C42 直柄-CK接柄

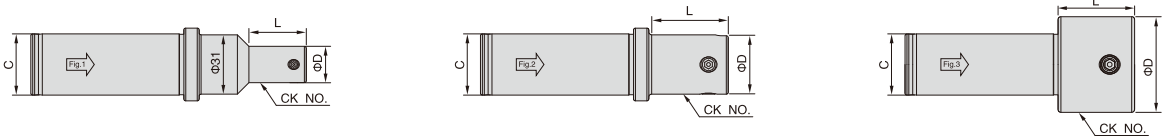

●使仅能夹持直柄的铣刀柄也能使用CK模块化系列刀具



订货型号	尺寸(mm)					螺钉	重量(Kg)
	C	CK NO.	L	ΦD	Fig.		
C32-CK1-30	32	CK1	30	19	1	CKS1	0.71
-CK2-35		CK2	35	24	2	CKS2	0.61
-CK3-40		CK3	40	31	2	CKS3	0.65
-CK4-40		CK4	40	40	3	CKS4	0.68
-CK5-40		CK5	40	48.5	3	CKS5	0.83
-CK6-50		CK6	50	63.5	3	CKS6	1.29
C42-CK5-40	42	CK5	40	48.5	3	CKS5	1.36
-CK6-50		CK6	50	63.5	3	CKS6	1.85
-CK7-60		CK7	60	83	3	CKS7	2.53

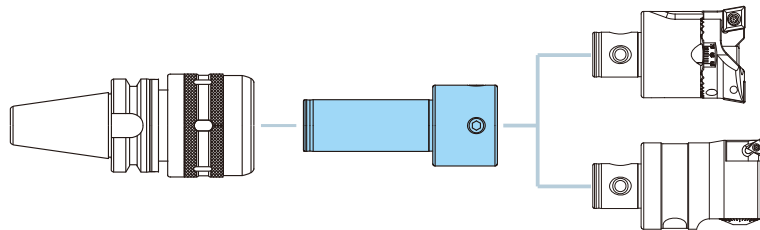

CK 接口模块化镗孔刀具

CK 延长接柄



●延长CK型主轴柄的加工深度

订货型号	尺寸(mm)					键	螺钉	重量(Kg)
	CK NO.1	CK NO.2	L	ΦD	Φd			
CK1-1-20L	CK1	CK1	20	19	9	----	CKS1	0.05
-30L			30					0.07
CK2-2-30L	CK2	CK2	30	24	12	CKSP2	CKS2	0.10
-45L			45					0.15
CK3-3-30L	CK3	CK3	30	31	16	CKSP3	CKS3	0.17
-45L			45					0.25
CK4-4-45L	CK4	CK4	45	40	20	CKSP4	CKS4	0.40
-60L			60					0.53
CK5-5-60L	CK5	CK5	60	48.5	26	CKSP5	CKS5	0.87
-90L			90					1.29
CK6-6-60L	CK6	CK6	60	63.5	34	CKSP6	CKS6	1.38
-100L			100					2.31
CK7-7-100L	CK7	CK7	100	83	42	CKSP7	CKS7	5.26

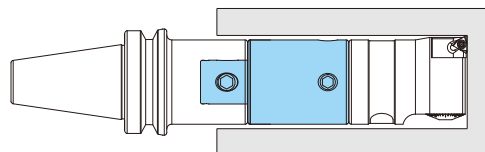
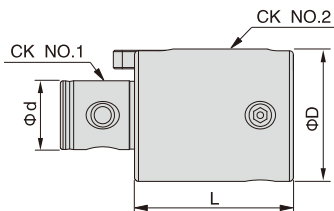

CK 接口模块化镗孔刀具

CK 缩径接柄

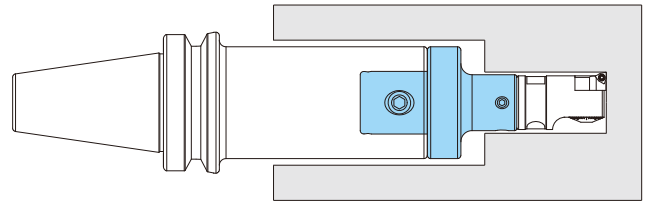

●使较大的CK接口转为较小的CK接口，在加工位置很深的孔时能最大限度的提高系统刚性

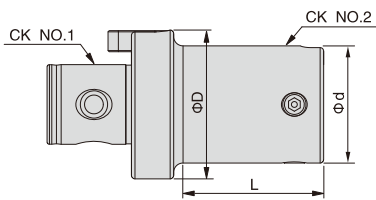

订货型号	尺寸(mm)					键	螺钉	重量 (Kg)
	CK NO.1	CK NO.2	L	ΦD	Φd			
CK2-1-45L	2	1	45	24	19	CKS2	CKS1	0.15
CK3-1-45L	3	1	45	31	24	CKS3	CKS1	0.21
-2-60L		2	60				CKS2	0.20
CK4-1-45L	4	1	45	40	24	CKS4	CKS1	0.26
-2-60L		2	60				CKS2	0.31
-3-60L		3	60				CKS3	0.30
CK5-1-60L	5	1	60	48.5	19	CKS5	CKS1	0.43
CK5-2-60L		2	60		24		CKS2	0.53
-90L		3	90		31		CKS3	0.59
CK5-3-60L		3	60		40		CKS4	0.60
-90L		4	90					0.66
CK5-4-60L		4	60			0.61		
-100L			100			1.16		
CK6-1-60L	6	1	60	63.5	19	CKSP6	CKS1	0.95
CK6-2-60L		2	60		24		CKS2	0.96
-90L		3	90		31		CKS3	1.15
CK6-3-60L		3	60		40		CKS4	0.94
-100L		4	100		48.5		CKS5	1.38
CK6-4-60L		4	60					0.99
-100L	5	100			1.50			
CK6-5-60L		5	60			1.55		
-100L			100			1.78		
CK7-6-60L	7	6	60	83	63.5	CKSP7	CKS6	3.38
-100L			100					

CK 接口模块化镗孔刀具

C20/C25/C32-CKB 延长接柄

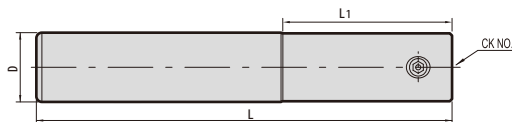

型号	D	L	L1	CK NO.
C20*100-CKB1	20	100	32	CKB1
C20*130-CKB1		130	62	
C20*170-CKB1		170	102	
C25*100-CKB2	25	100	35	CKB2
C25*125-CKB2		125	60	
C25*165-CKB2		165	100	
C25*215-CKB2		215	150	
C32*100-CKB3	32	100	30	CKB3
C32*160-CKB3		160	80	
C32*210-CKB3		210	140	

CK 接口模块化镗孔刀具

CK-CKB 缩径接柄

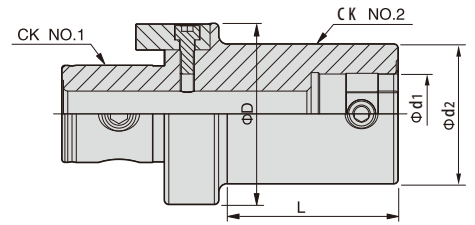

订货型号	尺寸(mm)						键	螺钉	重量 (kg)
	CK NO.1	CK NO.2	L	ΦD	Φd1	Φd2			
CK2-CKB1-45L	CK2	CKB1	45L	24	11	19	CKS2	CKS1	0.15
CK3-CKB1-45L	CK3	CKB1	45L	31	11	19	CKS3	CKS1	0.21
CK5-CKB4-60L	CK5	CKB4	60L	48.5	22	39	CKS5	CKS4	0.61
CK6-CKB5-60L	CK6	CKB5	60L	63.5	28	49	CKSP6	CKS5	1.55
CK7-CKB6-60L	CK7	CKB6	60L	83	36	63	CKSP7	CKS6	3.38
-100L			100L						3.65

CK 接口模块化镗孔刀具

CK-CKB 转换接柄

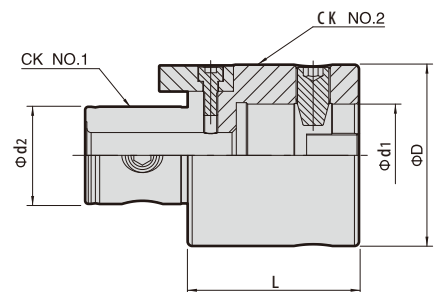

订货型号	尺寸(mm)						键	螺钉	重量 (kg)
	CK NO.1	CK NO.2	L	ΦD	Φd1	Φd2			
CK1-CKB1-20L -30L	CK1	CKB1	20	19	11	9	—	CKS1	0.05
			30						0.07
CK2-CKB2-30L -45L	CK2	CKB2	30	24	14	12	CKSP2	CKS2	0.1
			45						0.15
CK3-CKB3-30L -45L	CK3	CKB3	30	31	18	16	CKSP3	CKS3	0.17
			45						0.25
CK4-CKB4-45L -60L	CK4	CKB4	45	39	22	20	CKSP4	CKS4	0.4
			60						0.53
CK5-CKB5-60L -90L	CK5	CKB5	60	49	28	26	CKSP5	CKS5	0.87
			90						1.29
CK6-CKB6-60L -100L	CK6	CKB6	60	63	36	34	CKSP6	CKS6	1.38
			100						2.31

模块化镗孔刀具

RB-DK 大孔径粗镗刀-轻载

Φ218-670 通孔、台阶孔

DK-RB | 218310 | SC | -AL
 RB DK 镗刀系列 | 镗孔范围 | S型刀粒/带倾角 | 铝质

- 适用于卧式镗铣床和龙门铣床
- 滑轨与刀柄的连接部位有防止串位机构，具备足够的安全性
- 模块化结构，更换相关组件后成为精镗刀
- 中心内藏冷却液管路，可直接冷却刀尖切削部位

专利

☑ 可独立控制的刀具冷却液管路

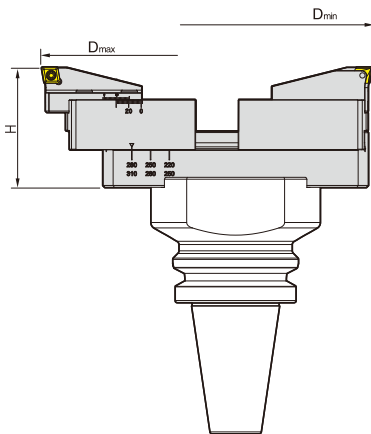

套件

类别	图样	订货型号 (不含主轴柄)	加工范围 ΦD	H	Kg (Kg)
轻载 (钢滑轨)		DK-RB 218310CC	218-310	96	7.9
		DK-RB 308400CC	308-400		9.8
		DK-RB 398490CC	398-490		11.7
		DK-RB 488580CC	488-580		16.9
		DK-RB 578670CC	578-670		21.9
		DK-RB 218310TC	218-310		7.9
		DK-RB 308400TC	308-400		9.8
		DK-RB 398490TC	398-490		11.7
		DK-RB 488580TC	488-580		16.9
		DK-RB 578670TC	578-670		21.9
		DK-RB 218310SC	218-310		7.9
		DK-RB 308400SC	308-400		9.8
DK-RB 398490SC		398-490	11.7		
DK-RB 488580SC		488-580	16.9		
DK-RB 578670SC		578-670	21.9		
轻载 (铝合金滑轨)		DK-RB 218310C-AL	218-310	114	6.0
		DK-RB 308400C-AL	308-400	114	6.7
		DK-RB 398490C-AL	398-490	119	7.6
		DK-RB 488580C-AL	488-580	129	9.2
		DK-RB 578670C-AL	578-670	139	10.7
		DK-RB 218310TC-AL	218-310	114	6.0
		DK-RB 308400TC-AL	308-400	114	6.7
		DK-RB 398490TC-AL	398-490	119	7.6
		DK-RB 488580TC-AL	488-580	129	9.2
		DK-RB 578670TC-AL	578-670	139	10.7
		DK-RB 218310SC-AL	218-310	114	6.0
		DK-RB 308400SC-AL	308-400	114	6.7
DK-RB 398490SC-AL		398-490	119	7.6	
DK-RB 488580SC-AL		488-580	129	9.2	
DK-RB 578670SC-AL		578-670	139	10.7	

订货示例:

- ◇ 1.大孔径粗镗刀1套，型号DK-RB 488580SC；选配主轴柄BT50-DK70-95
- ◇ 2.滑轨1条，型号DK70-488AU
- ◇ 3.小刀夹1对，型号DK70SC

组件订购说明:

- ◇ 组件中不包含主轴柄，请另外订购；
- ◇ 组件中包含桥式滑轨、滑块（2件/组）、刀夹（2件/组）。



模块化镗孔刀具

RB-DK 大孔径粗镗刀-轻载

Φ218-670 通孔、台阶孔

轻载刀夹:

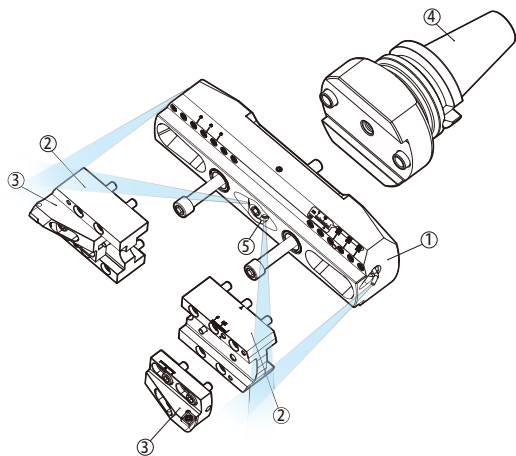

- 1.滑轨
- 2.滑块
- 3.刀夹
- 4.刀柄
- 5.冷却液喷管

组件订购说明:

- ◇各组件可单独订购;
- ◇滑块组件包含对称的2只, 不售单只;
- ◇小刀夹组件含对称的2只, 不售单只, 不包含刀片;
- ◇主轴柄、滑轨、滑块可共用于精镗刀。

RB-DK 轻载粗镗组件

镗孔范围	① 滑轨				L	② 滑块 (2个一组)		③ 小刀夹 (2个一组)		
	短悬伸		长悬伸			型号	Kg (Kg)	型号	Kg (Kg)	
	重型滑轨 (钢质)	(Kg)	轻型滑轨 (铝质)	(Kg)						
218-310	DK70-218AU	4.0	DK70-218AU-AL	2.8	DK70-BU	1.3	轻载刀夹	DK70CC	0.5	
308-400	DK70-308AU	5.9	DK70-308AU-AL	3.1				DK70TC	0.5	
398-490	DK70-398AU	7.8	DK70-398AU-AL	4.0				DK70SC	0.5	
488-580	DK70-488AU	13	DK70-488AU-AL	5.6			每个滑块包含: 订货型号:		每个刀夹包含: 订货型号:	
578-670	DK70-578AU	18	DK70-578AU-AL	7.1			锁紧螺钉*5个 垫圈*5个 定位销*1个	BM 08040 DW C-M 8 D 6-10L	锁紧螺钉*3个 垫圈*5个 调节螺钉*1个	BM 08020 DW C-M 8 CM 06035

刀夹组件选择引导

镗孔形式	工况	特点		刀夹			刀片型号
		优点	缺点	类别	刀夹型号	刀夹样式	
<p>通孔 盲孔 台阶孔</p>	<p>轻载 重载</p>	泛用, 通孔盲孔	刀片只有2个刃角, 经济性不够高	轻载刀夹	DK70CC		CC□□1204□□
		适应于机床或装夹刚性不足者, 经济性较好	抗冲击较差		DK70TC		TC□□16T3□□
		抗冲击较好, 刀片寿命长, 经济性好	只能镗通孔, 应用范围有局限性		DK70SC		SC□□1204□□

孔加工刀具 镗刀

模块化镗孔刀具

RB-DK 大孔径粗镗刀-重载

Φ218-670 通孔、台阶孔

DK-RB 218310 TCFNL - 12
 RBDK 镗刀系列 镗孔范围 刀头形式 刀片规格

- 适用于卧式镗铣床和龙门铣床
- 滑轨与刀柄的连接部位有防止串位机构，具备足够的安全性
- 模块化结构，更换相关组件后成为精镗刀
- 中心内藏冷却液管路，可直接冷却刀尖切削部位

专利

☑ 可独立控制的刀具冷却液管路

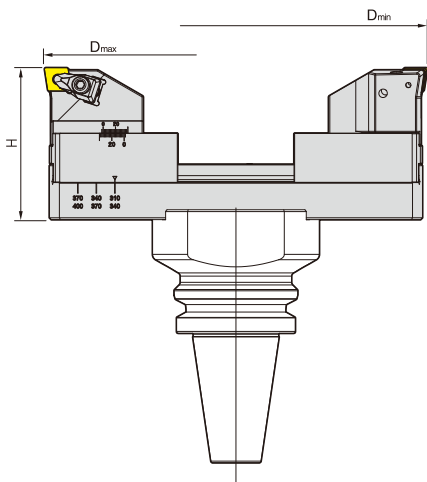

套件

类别	图样	订货型号 (不含主轴柄)	加工范围 ΦD	H	Kg (Kg)		
重载 (钢滑轨)		DK-RB218310TCFNL-12	218-310	140	8.3		
		DK-RB308400TCFNL-12	308-400		10.2		
		DK-RB398490TCFNL-12	398-490		12.1		
		DK-RB488580TCFNL-12	488-580		17.3		
		DK-RB578670TCFNL-12	578-670		22.3		
		DK-RB218310TSYNL-12	218-310	140	8.3		
		DK-RB308400TSYNL-12	308-400		10.2		
		DK-RB398490TSYNL-12	398-490		12.1		
		DK-RB488580TSYNL-12	488-580		17.3		
		DK-RB578670TSYNL-12	578-670		22.3		
			DK-RB218310TCFNL-19	218-310	160	8.86	
			DK-RB308400TCFNL-19	308-400		10.76	
DK-RB398490TCFNL-19			398-490	12.66			
DK-RB488580TCFNL-19			488-580	17.86			
		DK-RB578670TCFNL-19	578-670	22.86			
			DK-RB218310TSYNL-19	218-310		160	8.86
			DK-RB308400TSYNL-19	308-400			10.76
			DK-RB398490TSYNL-19	398-490			12.66
DK-RB488580TSYNL-19	488-580		17.86				
DK-RB578670TSYNL-19	578-670	22.86					

订货示例：

- ◇1.大孔径粗镗刀1套，型号DK-RB398490TCFNL-19；
选配主轴柄BT50-DK70-95
- ◇2.滑轨1条，型号DK70-398AU
- ◇3.小刀夹1对，型号DK70-TCFNL-19

组件订购说明：

- ◇组件中不包含主轴柄，请另外订购；
- ◇组件中包含桥式滑轨、滑块（2件/组）、刀夹（2件/组）。



模块化镗孔刀具

RB-DK 大孔径粗镗刀-重载

Φ218-670 通孔、台阶孔

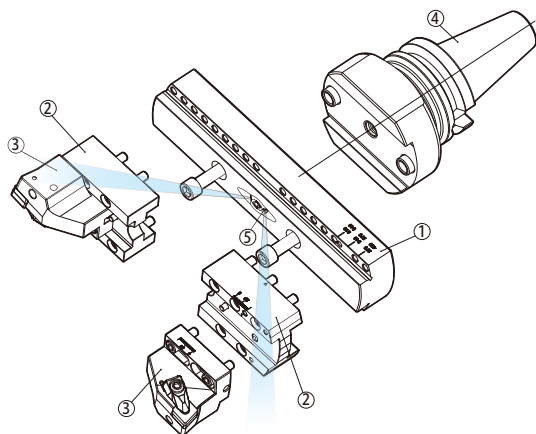

- 1.滑轨
- 2.滑块
- 3.刀夹
- 4.刀柄
- 5.冷却液喷管

滑块配件

滑块型号	订货型号		
	锁紧螺钉	垫圈	定位销
DK70-BU	BM 08040	DW C-M 8	D 6-10L

◇每个滑块包含：
锁紧螺钉*5个 / 垫圈*5个 / 定位销*1个

刀夹配件

刀夹型号	订货型号				
	锁紧螺钉	垫圈	调节螺钉	压板组件	刀垫组件
DK70-TCFNL-12	BM 08020	DW C-M 8	CM 06035	TCL04	TC1204
DK70-TSYNL-12				TCL04	TS1204
DK70-TCFNL-19				TCL06	TC1906
DK70-TSYNL-19				TCL06	TS1906

◇每个刀夹包含：
锁紧螺钉*3个 / 垫圈*5个 / 调节螺钉*1个 / 压板组件*1套 / 刀垫组件*1套

孔加工刀具 镗刀

RB-DK 重载粗镗组件

镗孔范围	① 重型滑轨 (钢质)			② 滑块 (2个一组)		③ 小刀夹 (2个一组)		
	型号	L	Kg (Kg)	型号	Kg (Kg)	型号	Kg (Kg)	
218-310	DK70-218AU	212	4.0	DK70-BU	1.3	重载刀夹	DK70-TCFNL-12	0.7
308-400	DK70-308AU	302	5.9				DK70-TSYNL-12	0.7
398-490	DK70-398AU	392	7.8				DK70-TCFNL-19	0.98
488-580	DK70-488AU	482	13				DK70-TSYNL-19	0.98
578-670	DK70-578AU	572	18					

组件订购说明:

- ◇各组件可单独订购;
- ◇滑块组件包含对称的2只, 不售单只;
- ◇小刀夹组件含对称的2只, 不售单只, 不包含刀片;
- ◇主轴柄、滑轨、滑块可共用于精镗刀。

模块化镗孔刀具

RB-DK 大孔径粗镗刀-重载

Φ218-670 通孔、台阶孔

重载刀夹:



DK70-T□□NL-12 刀夹配件表

配件形状	压板螺钉	弹簧	用于有孔刀片		用于无孔刀片	
			压板*	压板*	刀片	刀垫
配件型号	MS 05020	SP713	TCL04	TCL04A	CN□□1204□□ SN□□1204□□	TC1204 TS1204

* 注：可安装两种压板，分别用于安装有孔、无孔两种刀片。

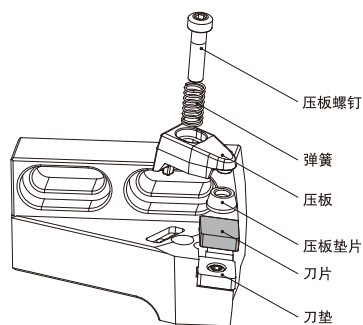

刀夹组件选择引导

镗孔形式	工况	特点		类别	刀夹		刀片型号
		优点	缺点		刀夹组件型号	刀夹样式	
通孔 盲孔 台阶孔	轻载 重载	泛用，通孔盲孔	负载较重，不适于小功率机床	重载刀夹	DK70-TCFNL-12		CN□□1204□□
		抗冲击较好，刀片寿命长，经济性好	只能镗通孔，应用范围有局限性		DK70-TSYNL-12		SN□□1204□□
		泛用，通孔盲孔、大切深	负载重，不适于小功率机床		DK70-TCFNL-19		CN□□1906□□
		抗冲击较好，刀片寿命长，大切深，经济性好	只能镗通孔，应用范围有局限性		DK70-TSYNL-19		SN□□1906□□

组件订购说明：

- ◇各组件可单独订购；
- ◇滑块组件包含对称的2只，不售单只；
- ◇小刀夹组件含对称的2只，不售单只，不包含刀片；
- ◇主轴柄、滑轨、滑块可共用于精镗刀。



模块化镗孔刀具

FB-DK 大孔径精镗刀

Φ218-670 通孔、台阶孔

- 模块化结构，更换相关组件后即成为大孔径粗镗头
- 中心内藏冷却液管路，可直接冷却刀尖切削部位

专利

☑ 可独立控制的刀具冷却液管路

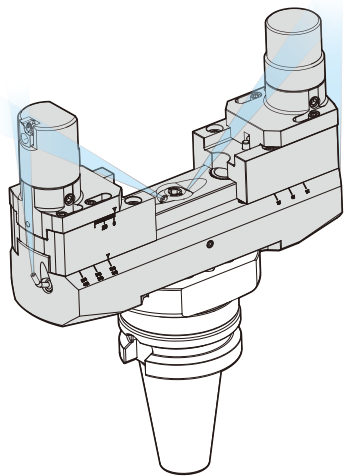

套 件				
订货型号 (不含主轴柄)		ΦD	H	Kg (Kg)
TP	TC			
DK-FB218310TP-AL	DK-FB218310TC-AL	218-310	180	7.13
DK-FB308400TP-AL	DK-FB308400TC-AL	308-400	180	7.73
DK-FB398490TP-AL	DK-FB398490TC-AL	398-490	185	8.63
DK-FB488580TP-AL	DK-FB488580TC-AL	488-580	195	10.23
DK-FB578670TP-AL	DK-FB578670TC-AL	578-670	205	11.73

- ◇ 组合中不包含主轴柄，请另外订购。
- ◇ 订购说明：

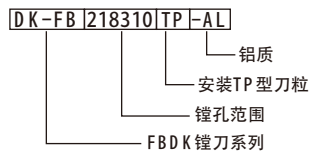

在大孔精镗时，特别是卧式加工中心上往往因为镗孔系统的不平衡而影响精度。使用平衡块可以提高镗孔的真圆度，维持高精度加工。

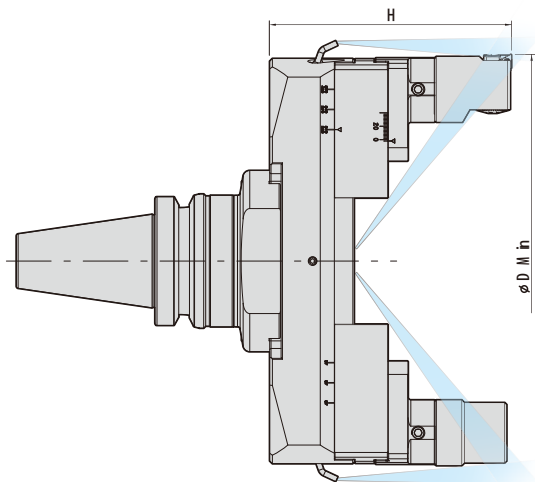

- ◇ 订货说明：
- 1. 组合中不包含主轴柄，请另外订购。
- 2. 各组件可以单独销售。
- 3. 精镗刀架不附带刀片，请另外订购。
- 4. 主轴柄、滑轨、滑块是粗、精镗通用件。



模块化镗孔刀具

FB-DK 大孔径精镗刀

Φ218-670 通孔、台阶孔

- 1.滑轨
- 2.滑块
- 3.过度滑块
- 4.精镗刀架
- 5.平衡块
- 6.刀柄
- 7.冷却液喷管

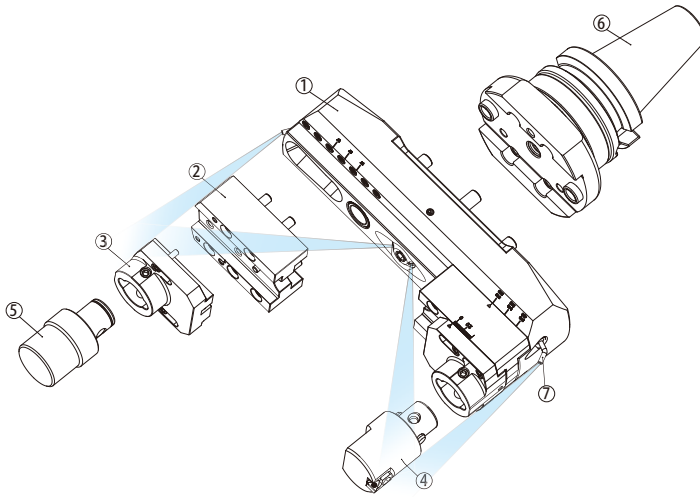

滑块配件

滑块型号	订货型号		
	锁紧螺钉	垫圈	定位销
DK70-BU	BM 08040	DWC-M8	D6-10L

◇每个滑块包含：
锁紧螺钉*5个 / 垫圈*5个 / 定位销*1个

过度滑块

过度滑块型号	订货型号		
	锁紧螺钉	CK 锥型螺钉	调节螺钉
DK70-CU	BM 06020	CK S5	CM 06035

◇每个过度滑块包含：
锁紧螺钉*3个 / CK 锥型螺钉*2个 / 调节螺钉*1个

FB-DK精镗组件

镗孔范围	① 轻型滑轨 (铝质)			② 滑块 (2个一组)		③ 过渡滑块 (2个一组)		④ 精镗刀架		⑤ 平衡块	
	型号	L	Kg (Kg)	型号	Kg (Kg)	型号	Kg (Kg)	型号	Kg (Kg)	型号	Kg (Kg)
218-310	DK70-218AU-AL	212	2.8								
308-400	DK70-308AU-AL	302	3.1								
398-490	DK70-398AU-AL	392	4.0								
488-580	DK70-488AU-AL	482	5.6	DK70-BU	1.3	DK70-CU	0.58	EW N53-95-CKB5-TP EW N53-95-CKB5-TC	0.42	NB-BR	0.45
578-670	DK70-578AU-AL	572	7.1								

◇各组件订货示例：

- 1.滑轨1条, 型号DK70-218AU-AL
- 2.精镗刀架1件, 型号EW N53-95-CKB5-TP



模块化镗孔刀具

加高滑块

● 装配应用示例

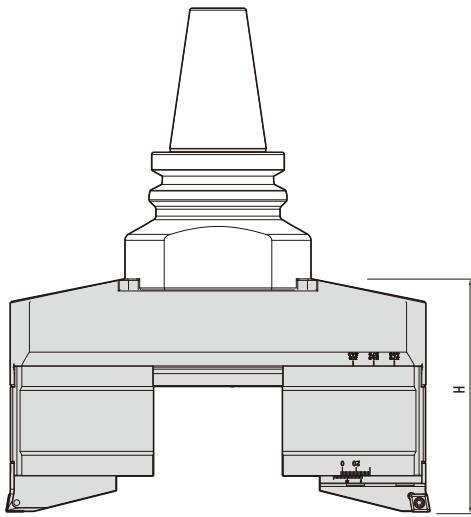

粗镗加高滑块

订货型号	镗刀高度 H		Kg
	安装轻载刀夹	安装重载刀夹	
DK 70-DU	169	190	2.0

加高滑块 (2个一组)

1. 刀夹
2. 加高滑块
3. 滑轨
4. 刀柄

孔加工刀具
镗刀

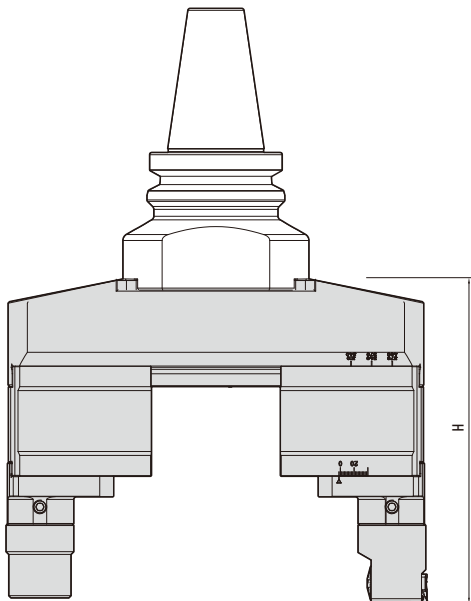

精镗加高滑块

订货型号	镗刀高度 H		Kg
	安装轻载刀夹	安装重载刀夹	
DK 70-DU	235	235	2.0

加高滑块 (2个一组)

1. 平衡块
2. 精镗刀架
3. 过度滑块
4. 加高滑块
5. 滑轨
6. 刀柄

模块化镗孔刀具

套镗-粗镗刀-常规滑块

加工范围：Φ7-367

专利

☑ 可独立控制的刀具冷却液管路

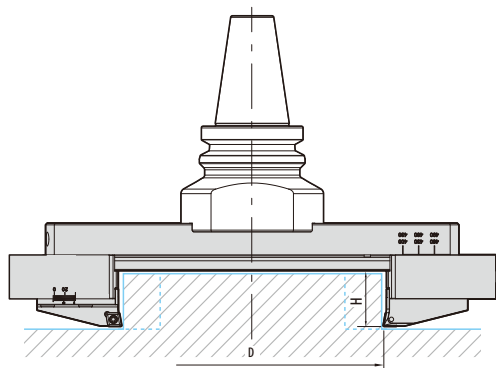

◇ 轻载镗刀型号编制说明：

DK-RB 218310 SC

RBDK 镗刀系列 镗孔范围 S型刀粒/带倾角

◇ 重载镗刀型号编制说明：

DK-RB 218310 TCFNL - 12

RBDK 镗刀系列 镗孔范围 刀头形式 刀片规格

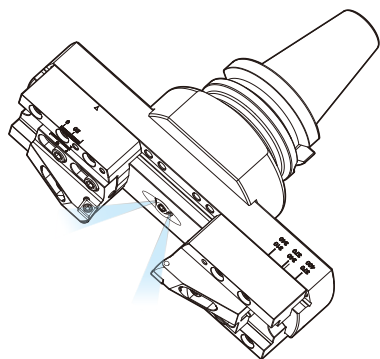

套镗-粗镗刀常规滑块套件

类别	加工范围 ΦD	订货型号 (不含主轴柄)	H	重量 (Kg)
轻载 (钢滑轨)	7-37	DK-RB 218310C C	96	7.9
	37-97	DK-RB 308400C C		9.8
	67-187	DK-RB 398490C C		11.7
	97-277	DK-RB 488580C C		16.9
	127-367	DK-RB 578670C C		21.9
	7-37	DK-RB 218310TC		7.9
	37-97	DK-RB 308400TC	9.8	
	67-187	DK-RB 398490TC	11.7	
	97-277	DK-RB 488580TC	16.9	
	127-367	DK-RB 578670TC	21.9	
	7-37	DK-RB 218310S C	7.9	
	37-97	DK-RB 308400S C	9.8	
67-187	DK-RB 398490S C	11.7		
97-277	DK-RB 488580S C	16.9		
127-367	DK-RB 578670S C	21.9		
重载 (钢滑轨)	7-37	DK-RB 218310TC FN L-12	140	8.3
	37-97	DK-RB 308400TC FN L-12		10.2
	67-187	DK-RB 398490TC FN L-12		12.1
	97-277	DK-RB 488580TC FN L-12		17.3
	127-367	DK-RB 578670TC FN L-12		22.3
	7-37	DK-RB 218310TSYN L-12		8.3
	37-97	DK-RB 308400TSYN L-12	10.2	
	67-187	DK-RB 398490TSYN L-12	12.1	
	97-277	DK-RB 488580TSYN L-12	17.3	
	127-367	DK-RB 578670TSYN L-12	22.3	
	7-37	DK-RB 218310TC FN L-19	160	8.86
	37-97	DK-RB 308400TC FN L-19		10.76
	67-187	DK-RB 398490TC FN L-19		12.66
	97-277	DK-RB 488580TC FN L-19		17.86
	127-367	DK-RB 578670TC FN L-19		22.86
	7-37	DK-RB 218310TSYN L-19		8.86
	37-97	DK-RB 308400TSYN L-19	10.76	
	67-187	DK-RB 398490TSYN L-19	12.66	
97-277	DK-RB 488580TSYN L-19	17.86		
127-367	DK-RB 578670TSYN L-19	22.86		

孔加工刀具 镗刀



模块化镗孔刀具

套镗-粗镗刀-加高滑块

加工范围：Φ7-367

专利

☑ 可独立控制的刀具冷却液管路

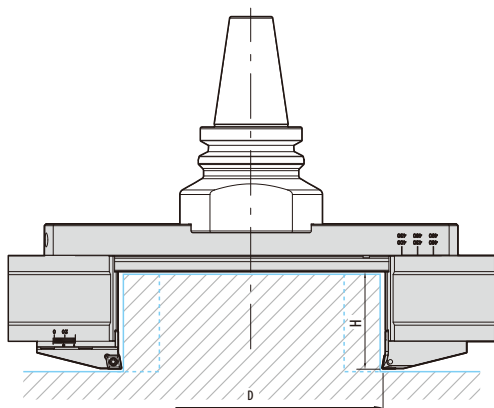

◇ 轻载镗刀型号编制说明：

DK-RB | 218310 | SC | -AL | -H
 RBDK 镗刀系列 | 镗孔范围 | S型刀粒/带倾角 | 铝合金 | 加高

◇ 重载镗刀型号编制说明：

DK-RB | 218310 | TCFNL | -12 | -H
 RBDK 镗刀系列 | 镗孔范围 | 刀头形式 | 刀片规格 | 加高

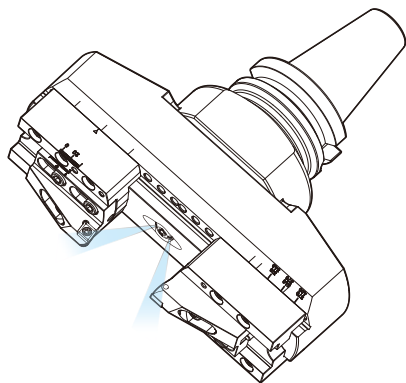

套镗-粗镗刀加高滑块套件

类别	加工范围 ΦD	订货型号 (不含主轴柄)	H	Kg (Kg)
轻载 (铝合金滑轨)	7-37	DK-RB218310C-AL-H	169	7.0
	37-97	DK-RB308400C-AL-H		7.6
	67-187	DK-RB398490C-AL-H		9.0
	97-277	DK-RB488580C-AL-H		10.6
	127-367	DK-RB578670C-AL-H		12
	7-37	DK-RB218310TC-AL-H	169	7.0
	37-97	DK-RB308400TC-AL-H		7.6
	67-187	DK-RB398490TC-AL-H		9.0
	97-277	DK-RB488580TC-AL-H		10.6
	127-367	DK-RB578670TC-AL-H		12
	7-37	DK-RB218310S-AL-H	169	7.0
	37-97	DK-RB308400S-AL-H		7.6
	67-187	DK-RB398490S-AL-H		9.0
	97-277	DK-RB488580S-AL-H		10.6
	127-367	DK-RB578670S-AL-H		12
重载 (钢滑轨)	7-37	DK-RB218310TCFNL-12-H	190	7.4
	37-97	DK-RB308400TCFNL-12-H		8.0
	67-187	DK-RB398490TCFNL-12-H		9.4
	97-277	DK-RB488580TCFNL-12-H		11
	127-367	DK-RB578670TCFNL-12-H		12.4
	7-37	DK-RB218310TSYNL-12-H	190	7.4
	37-97	DK-RB308400TSYNL-12-H		8.0
	67-187	DK-RB398490TSYNL-12-H		9.4
	97-277	DK-RB488580TSYNL-12-H		11
	127-367	DK-RB578670TSYNL-12-H		12.4
	7-37	DK-RB218310TCFNL-19-H	196	8.0
	37-97	DK-RB308400TCFNL-19-H		8.6
	67-187	DK-RB398490TCFNL-19-H		10
	97-277	DK-RB488580TCFNL-19-H		11.6
	127-367	DK-RB578670TCFNL-19-H		13
7-37	DK-RB218310TSYNL-19-H	196	8.0	
37-97	DK-RB308400TSYNL-19-H		8.6	
67-187	DK-RB398490TSYNL-19-H		10	
97-277	DK-RB488580TSYNL-19-H		11.6	
127-367	DK-RB578670TSYNL-19-H		13	

模块化镗孔刀具

扩展套镗-粗镗

专利

☑ 可独立控制的刀具冷却液管路

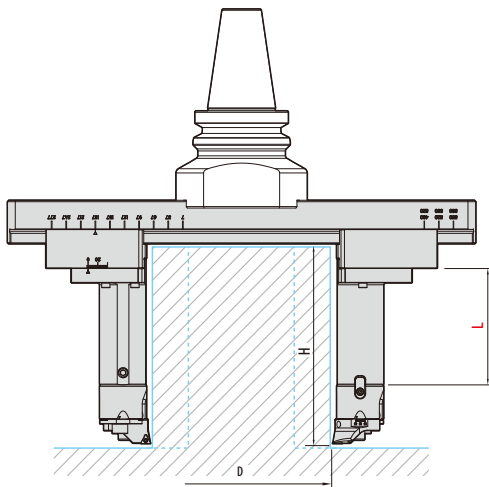

名称	订货型号	**
过度滑块	DK70-CU-CK5-**	订制长度
粗镗头	CK5-CT5674**	刀夹可选C/SA/T

- ◇ 套镗有效高度 $H = 85 + L$
过度滑块可订制加长尺寸（型号如上表），获得套镗的有效高度。
- ◇ 套镗有效直径范围D，参照前页C044。
- ◇ 套镗选用镗头CK5-CT5674，参照前页C028。
- ◇ 刀夹样式CT56C / CT56SA / CT56T，参照前页C029。

1. 滑轨*1条
2. 滑块*1组（2个）
3. 过度滑块*1组（2个）
4. 粗镗头*2组
5. 刀柄*1个

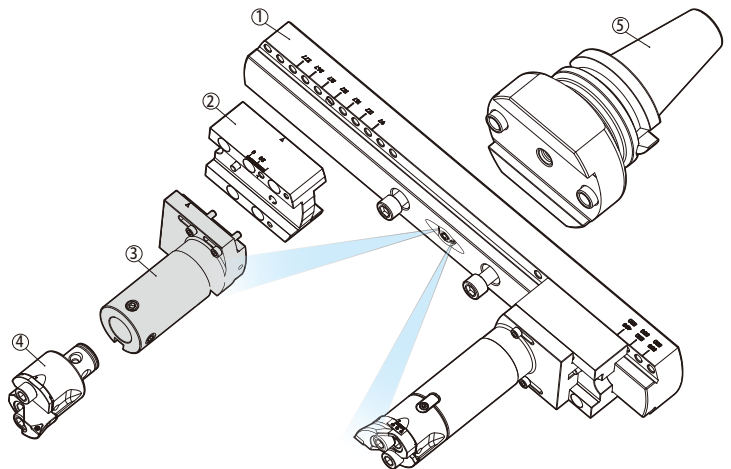

过度滑块可订制加长尺寸，实现更大范围的套镗

模块化镗孔刀具

套镗-精镗刀-常规滑块

加工范围：Φ7-367

专利

☑ 可独立控制的刀具冷却液管路

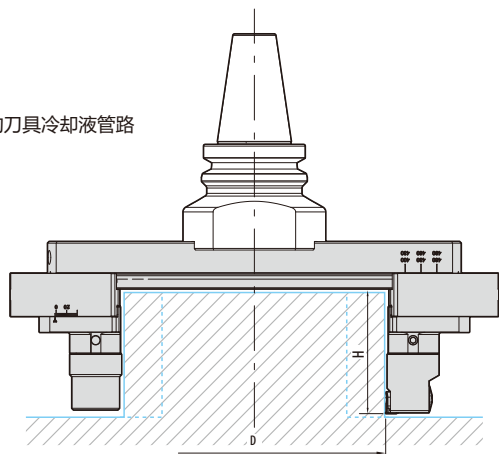

常规滑块套件				
订货型号 (不含主轴柄)		加工范围		Kg (Kg)
TP	TC	ΦD	H	
DK-FB218310TP	DK-FB218310TC	7-37	162	8.9
DK-FB308400TP	DK-FB308400TC	37-97		10.8
DK-FB398490TP	DK-FB398490TC	67-187		12.7
DK-FB488580TP	DK-FB488580TC	97-277		17.9
DK-FB578670TP	DK-FB578670TC	127-367		22.9

◇ 组合中不包含主轴柄，请另外订购。

◇ 订购说明：

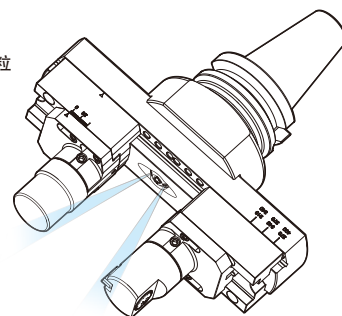
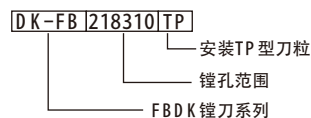

模块化镗孔刀具

套镗-精镗刀-加高滑块

加工范围：Φ7-Φ367

专利

☑ 可独立控制的刀具冷却液管路

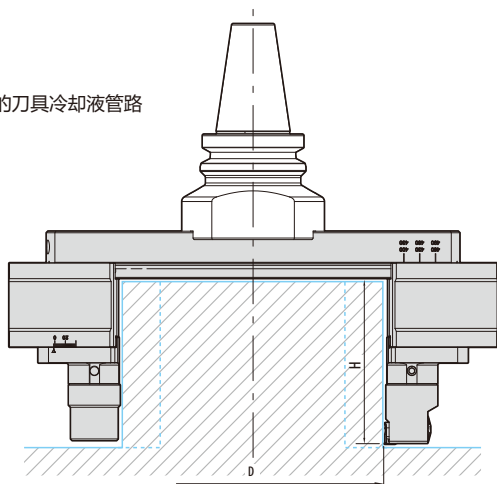

加高滑块套件				
订货型号 (不含主轴柄)		加工范围		Kg (Kg)
TP	TC	ΦD	H	
DK-FB218310TP-H	DK-FB218310TC-H	7-37	235	7.5
DK-FB308400TP-H	DK-FB308400TC-H	37-97		8
DK-FB398490TP-H	DK-FB398490TC-H	67-187		9.5
DK-FB488580TP-H	DK-FB488580TC-H	97-277		11
DK-FB578670TP-H	DK-FB578670TC-H	127-367		12.5

◇ 组合中不包含主轴柄，请另外订购。

◇ 订购说明：

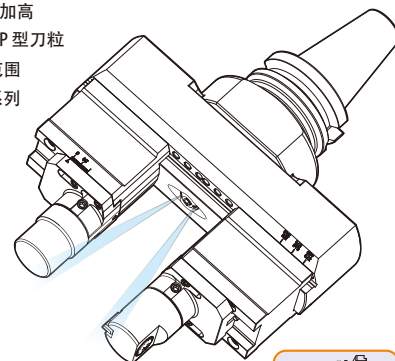

孔加工刀具
镗刀

模块化镗孔刀具

扩展套镗-精镗

专利

☑ 可独立控制的刀具冷却液管路

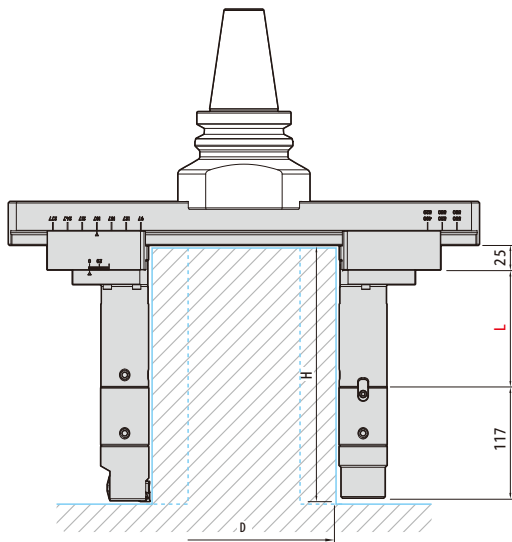

名称	订货型号	**
过度滑块	DK70-CU-CK-CKB-CKB5- ** L	订制长度
精镗头	EW N53-95CKB5 **	刀夹可选TP/TC

- ◇套镗有效高度 $H = 142 + L$
过度滑块可订制加长尺寸（型号如上表），获得套镗的有效高度。
- ◇套镗有效直径范围D，参照前页C047。
- ◇转换接柄选用CK5-CKB5-60L，参照前页C035。
- ◇精镗选用镗头EW N53-95CKB5，参照前页C030。
- ◇刀夹样式ENH5-1-TP / ENH5-1-TC，参照前页C030。

1. 滑轨*1条
2. 滑块*1组 (2个)
3. 过度滑块*1组 (2个)
4. 转换接柄*1组 (2个)
5. 精镗头*1个
6. 平衡块*1个
7. 刀柄*1个

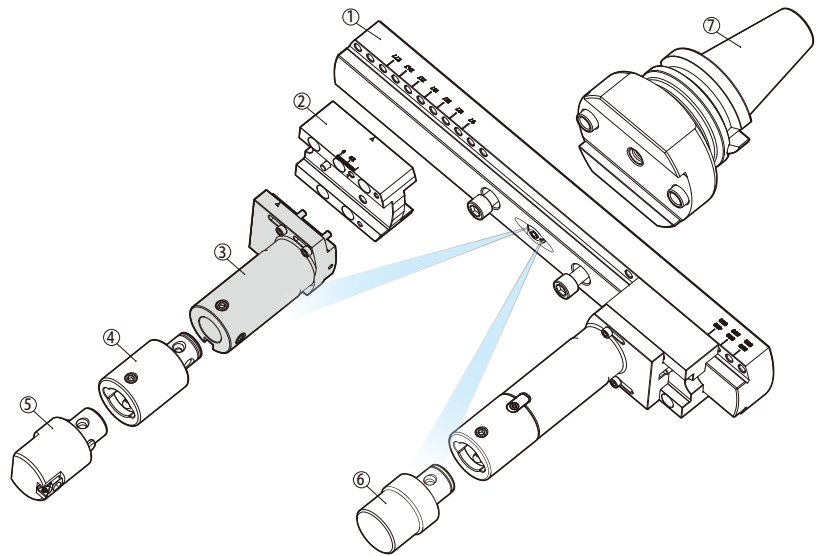

过度滑块可订制加长尺寸，实现更大范围的套镗

模块化镗孔刀具
短型号主轴柄

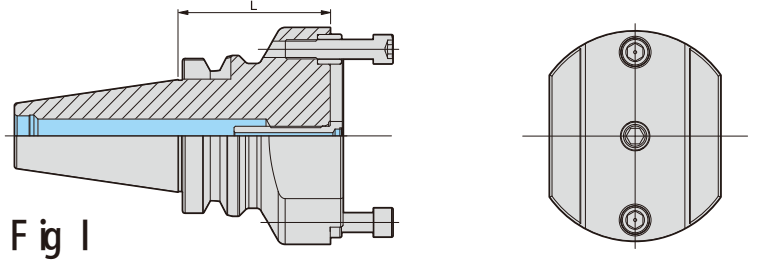

Fig I

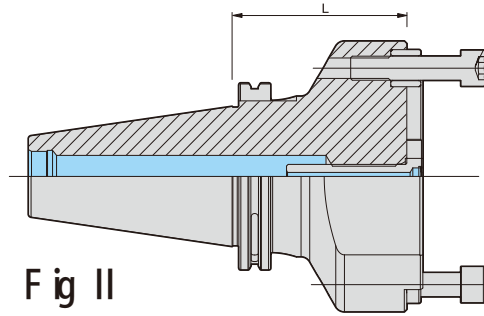

Fig II

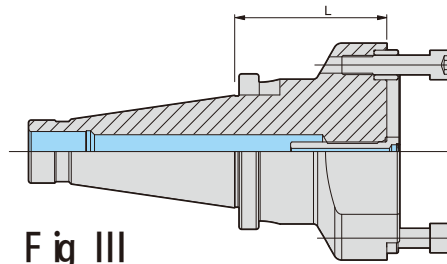

Fig III

孔加工刀具
镗刀

主轴柄	订货型号	Fig	尺寸 L (mm)	重量 (Kg)	螺钉	弹性垫圈	销
M AS 403 BT/BBT	BT50-S100N-DK70-95 BBT50-S100N-DK70-95	I	95	8.3	BM12060	SW-M12	DK70-PIN
D IN 69871A DAT/SK	DAT50-DK70-95	II	95	7.8	BM12060	SW-M12	DK70-PIN
D IN 2080 NT/ST	NT50(M)-DK70-95	III	95	7.2	BM12060	SW-M12	DK70-PIN

◇NT-DK型主轴柄公英制订货型号不同，具体如下：

NT50-DK70-95为英制型号

NT50M-DK70-95为公制型号

模块化镗孔刀具

长型号模块驳接主轴柄

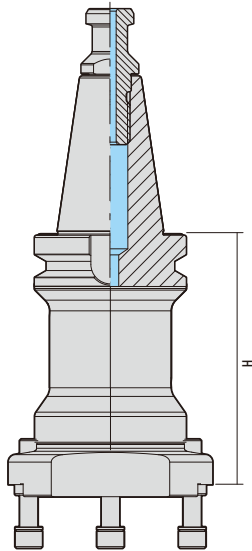

主轴柄

BT/BBT50
S 100N -

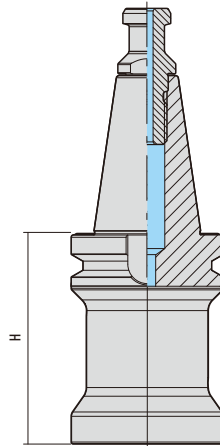

HSK-T100

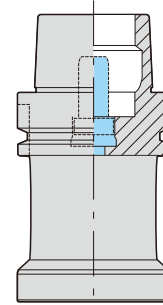

C 8

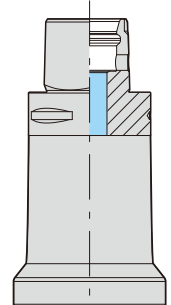

S 100N
镗刀接续模块
S 100N-DK70

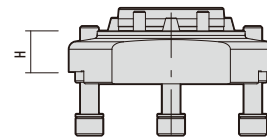

DK 镗刀组件

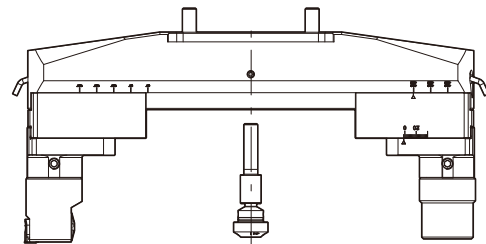

主轴柄	订货型号	H (mm)	重量 (Kg)	模块			
				基础柄模块	H	接续模块	H
DIN 69893-A HSK-100A	HSK-100A-S100N-DK70-110	110	6.2	HSK-100A-S100N-75	75	S 100N-DK70-35	35
	HSK-100A-S100N-DK70-175	175	8.1	HSK-100A-S100N-140	140		
MAS 403 BT50	BT50-S100N-DK70-95	95	6.4	BT50-S100N-60	60		
	BT50-S100N-DK70-115	115	7.6	BT50-S100N-80	80		
	BT50-S100N-DK70-175	175	9.1	BT50-S100N-140	140		
MAS 403 Big-Plus BBT50	BBT50-S100N-DK70-95	95	6.3	BBT50-S100N-60	60		
	BBT50-S100N-DK70-115	115	7.5	BBT50-S100N-80	80		
	BBT50-S100N-DK70-175	175	9.0	BBT50-S100N-140	140		
DIN 69871A DAT50	DAT50-S100N-DK70-95	95	6.2	DAT50-S100N-60	60		
	DAT50-S100N-DK70-115	115	7.3	DAT50-S100N-80	80		
	DAT50-S100N-DK70-175	175	8.8	DAT50-S100N-140	140		

模块化镗孔刀具

更多驳接

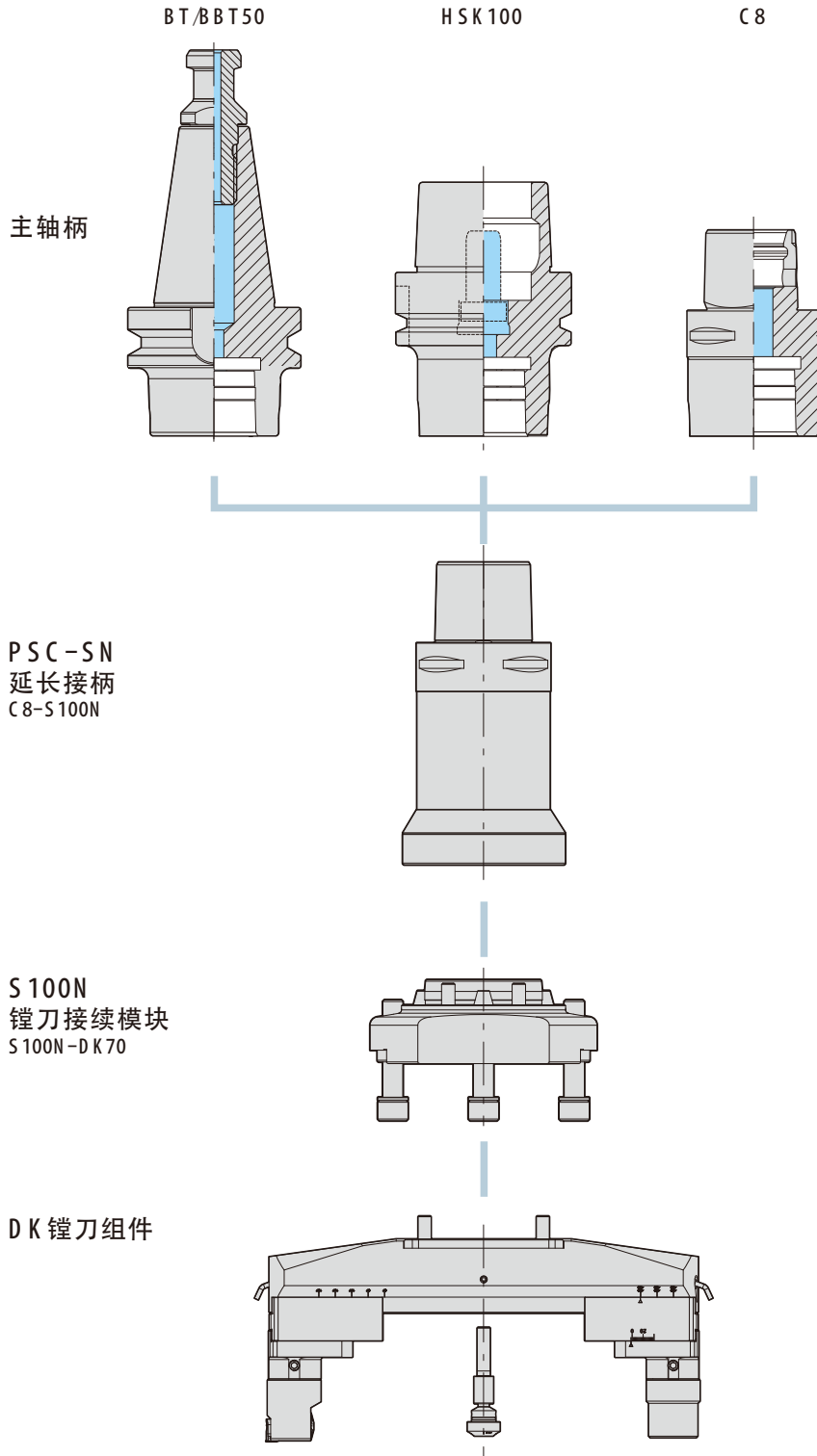

更多驳接，请参照亚肯样本E（亚肯多任务--旋转类工具系统）

孔加工刀具
镗刀

组合镗刀

NBJ16 微调精镗孔系统-套装

镗孔范围：Φ6-51

- 偏心行程较小，可以使用较高的转速
- 丰富的备选镗杆，满足您不同的加工需求



孔加工刀具
镗刀

标准套装	说明	主轴柄型号
BT40-NBJ16-8P	标准套装 附带8支镗杆 镗孔范围Φ8-Φ51 另备有可镗Φ6孔的 镗杆如有需要请另外订购	BT40-NBJ-55
BT50-NBJ16-8P		BT50-NBJ-65
DAT40-NBJ16-8P		DAT40-NBJ-60
DAT50-NBJ16-8P		DAT50-NBJ-65
无镗杆套装	说明	主轴柄型号
BT40-NBJ16	主轴柄与镗头套装，不含镗杆 镗孔范围Φ6-Φ51	BT40-NBJ-55
BT50-NBJ16		BT50-NBJ-65
DAT40-NBJ16		DAT40-NBJ-60
DAT50-NBJ16		DAT50-NBJ-65

◇ 本页规格为套装组合，主轴柄、精镗头、镗刀杆均可单独订购。

◇ 套装订货示例：

1. BT型：BT50-NBJ16-8P

2. BT型(不含镗刀杆)：BT50-NBJ16



组合镗刀

NBJ16 微调精镗孔系统-组件

镗孔范围：Φ6-51

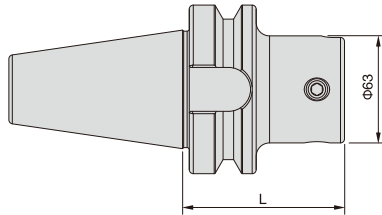

NBJ16 主轴柄

型号	L(mm)	重量 (Kg)
BT40-NBJ-55	55	1.26
BT50-NBJ-65	65	3.79
DAT40-NBJ-60	60	1.21
DAT50-NBJ-65	65	2.80

◇ 订货示例：
1. BT型：BT40-NBJ-55

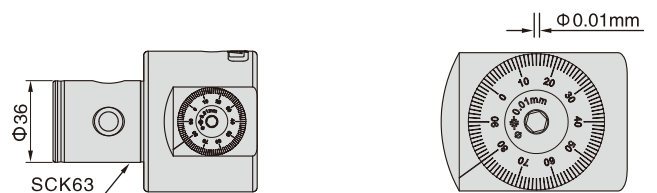

NBJ16 精镗头

型号	调整精度	调整行程	重量 (Kg)
NBJ16	Φ0.01mm/格	6mm	1.2Kg

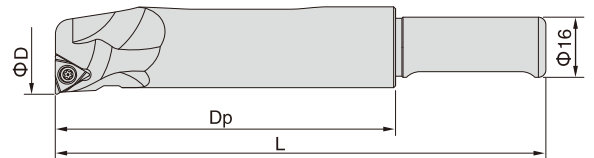
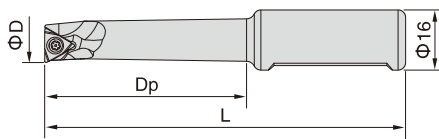

NBJ 精镗刀杆

型号	镗孔范围 ΦD	尺寸(mm)		通用刀片	螺钉	扳手
		Dp	L			
NBJ-1606-24 ※	Φ6 - Φ9	24	74	WBGT0601.L	R 20035J	T6
NBJ-1608-32	Φ8 - Φ11	32	86	TBGT0601.L	R 20050J	T6
NBJ-1610-40	Φ10 - Φ13	40	86			
NBJ-1612-53	Φ12 - Φ15	53	96	TPGH0902.L	R 25060G	T8
NBJ-1614-60 ※	Φ14 - Φ17	60	103			
NBJ-1616-68	Φ16 - Φ21	68	110	TPGH1103.L	R 30070E	T8
NBJ-1620-83	Φ20 - Φ26	83	123.5			
NBJ-1625-90	Φ25 - Φ31	90	130.5			
NBJ-1630-90	Φ30 - Φ36	90	130.5			
NBJ-1635-90 ※	Φ35 - Φ41	90	130.5			
NBJ-1640-90	Φ40 - Φ46	90	130.5			
NBJ-1645-90 ※	Φ45 - Φ51	90	130.5			

◇ 本页规格为单独组件，整套订购请查阅上一页
 ◇ 镗杆型号带※的为8支装组合之外的特别附件，您可以在需要时再订购。
 ◇ 精镗刀杆不附带刀片，请另外订购。

◇ 组件订货示例：
 1. 精镗头1件，型号NBJ16
 2. 精镗刀杆1件，型号NBJ-1608-32

组合镗刀

NBH2084 微调精镗孔系统-套装

镗孔范围：Φ8-280

- 较大的镗孔范围使系统有更广泛的适用领域。



孔加工刀具
镗刀

标准套装	说明	主轴柄型号
BT40-NBH2084-3P	3P精简版套装附带3支镗杆 镗孔范围Φ12-Φ280	R8-NBH
BT50-NBH2084-3P		BT40-NBH-50B
BT40-NBH2084-8P		BT50-NBH-55B
BT50-NBH2084-8P	8P标准版套装附带8支镗杆 镗孔范围Φ8-Φ280	BT50-NBH-100A
无镗杆套装	说明	主轴柄型号
BT40-NBH2084	主轴柄与镗头套装不包含镗杆	DAT40-NBH
BT50-NBH2084		DAT50-NBH

◇本页规格为套装组合，主轴柄、精镗头、镗刀杆均可单独订购。

◇套装订货示例：

1.BT型：BT50-NBH2084-8P

2.BT型(不含镗刀杆)：BT50-NBH2084

组合镗刀

NBH2084 微调精镗孔系统-组件

镗孔范围：Φ8-280

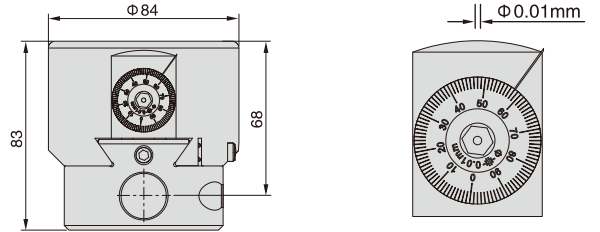

NBH2084 精镗头

型号	调整精度	调整行程	重量
NBH2084	Φ0.01mm/格	28mm	3.0Kg

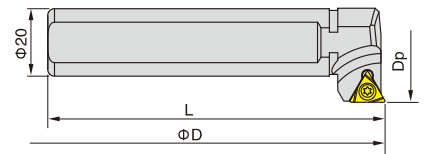
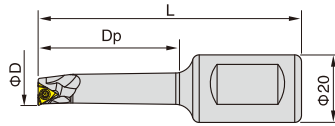

NBH 精镗刀杆

型号	简装版镗孔范围	标准版镗孔范围	尺寸(mm)		适用刀片	螺钉	扳手
			Dp	L			
NBH-2008-32	---	Φ8-Φ11	32	78	TBGT0601..L	R 20050J	T6
NBH-2010-40	---	Φ10-Φ13	40	78			
NBH-2012-53※	Φ12-Φ21	Φ12-Φ17	53	88	TPGH0902..L	R 25060G	T8
NBH-2016-68	---	Φ16-Φ21	68	103			
NBH-2020-83※	Φ20-Φ130	Φ20-Φ130	83	116	TPGH1103..L	R 30070E	T8
NBH-2025-96	---	Φ25-Φ135	96	135			
NBH-2030-115	---	Φ30-Φ140	115	154			
NBH-20120-L※	Φ120-Φ280	Φ120-Φ280	84+BTL	100			

- ◇ 本页规格为单独组件，整套订购请查阅上一页
- ◇ 镗杆型号带※的为精简版3支装组合。
- ◇ 精镗刀杆不附带刀片，请另外订购。
- ◇ 组件订货示例：
 1. 精镗头1件，型号NBH2084
 2. 精镗刀杆1件，型号NBH-20120-L

孔加工刀具
镗刀



简易镗

CT-MT 莫氏柄粗镗刀

Φ20-115 通孔、盲孔、台阶孔

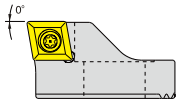

盲孔用 C型

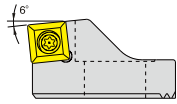

通孔用 SA型

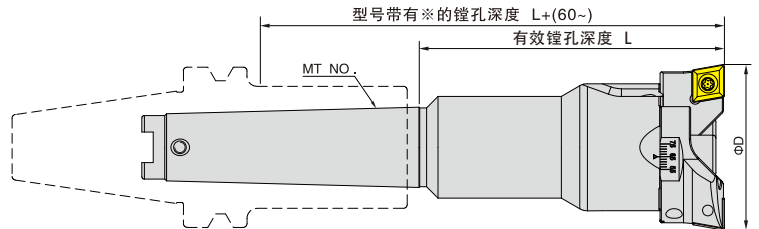

安装扁销后
即可使用M TA基础柄

扁销	螺钉
M TB2-M TA2	CM 04008
M TB3-M TA3	CM 05010
M TB4-M TA4	CM 06012
M TB5-M TA5	CM 08020

订货型号 (套件)	镗孔范围ΦD	尺寸(mm)		适用刀片	重量 (Kg)
		MT NO.	L		
CT2025C-MT2-60 -100	20-25	MT2	60 100	CCMT060204	0.20 0.29
CT2530C-MT3-75 -120	25-30	MT3	75 120	CCMT060204	0.38 0.53
CT2937C-MT3-75 -120	29-37	MT3	75 120	CCMT060204	0.43 0.57
CT3646C-MT3-100 -150	36-46	MT3	100 150	CCMT060204	0.71 0.98
CT4557C-MT4-120 -180	45-57	MT4	120 180	CCMT09T308	1.35 1.87
CT5674C-MT5-150 -225	56-74	MT5	150 225	CCMT120408	2.97 3.96
CT5674C-MT4-120※	56-74	MT4	120※	CCMT120408	1.57
CT7391C-MT4-90 ※	73-91	MT4	90 ※	CCMT120408	1.76
CT7391C-MT5-120※	73-91	MT5	120※	CCMT120408	2.95
CT90115C-MT5-90※	90-115	MT5	90 ※	CCMT120408	3.25
CT4557SA-MT4-120 -180	45-57	MT4	120 180	SCMT09T308	1.35 1.87
CT5674SA-MT5-150 -225	56-74	MT5	150 225	SCMT120408	2.97 3.96
CT5674SA-MT4-120※	56-74	MT4	120※	SCMT120408	1.57
CT7391SA-MT4-90 ※	73-91	MT4	90 ※	SCMT120408	1.76
CT7391SA-MT5-120※	73-91	MT5	120※	SCMT120408	2.95
CT90115SA-MT5-90※	90-115	MT5	90 ※	SCMT120408	3.25

◇刀片需单独订购。

◇订货示例：莫氏柄粗镗刀1套 型号CT5674SA-MT4-120

◇型号编制说明：
 [CT] [5674] [SA] - [MT4] - [120] - 镗孔深度
 ————— 莫氏柄型号
 ————— S型刀片
 ————— 镗孔范围
 ————— CT-MT系列镗刀

简易镗

CT-C 直柄粗镗刀

Φ20-115 通孔、盲孔、台阶孔

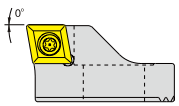

盲孔用 C型

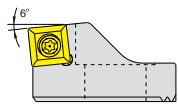

通孔用 SA型

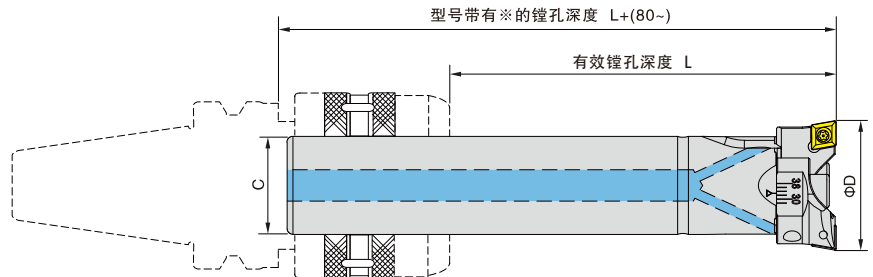

孔加工刀具
镗刀

订货型号 (套件)	镗孔范围ΦD	尺寸(mm)		适用刀片	重量 (Kg)
		C	L		
CT2025C-C 20-60 -100	20-25	C20	60 100	CCMT060204	0.22 0.31
CT2530C-C 25-75 -120	25-30	C25	75 120	CCMT060204	0.40 0.55
CT2937C-C 25-75 -120	29-37	C25	75 120	CCMT060204	0.46 0.61
CT3646C-C 32-100 -150	36-46	C32	100 150	CCMT060204	0.88 1.16
CT4557C-C 32-100 -150	45-57	C32	100 150	CCMT09T308	1.03 1.31
CT4557C-C 42-120 -180	45-57	C42	120 180	CCMT09T308	1.76 2.31
CT5674C-C 32-150	56-74	C32	150	CCMT120408	1.52
CT5674C-C 42-150	56-74	C42	150	CCMT120408	2.22
CT7391C-C 32-75*	73-91	C32	75*	CCMT120408	1.86
CT7391C-C 42-150	73-91	C42	150	CCMT120408	2.60
CT90115C-C 42-80*	90-115	C42	80*	CCMT120408	3.30
CT4557SA-C 32-100 -150	45-57	C32	100 150	SCMT09T308	1.03 1.31
CT4557SA-C 42-120 -180	45-57	C42	120 180	SCMT09T308	1.76 2.31
CT5674SA-C 32-150	56-74	C32	150	SCMT120408	1.52
CT5674SA-C 42-150	56-74	C42	150	SCMT120408	2.22
CT7391SA-C 32-75*	73-91	C32	75*	SCMT120408	1.86
CT7391SA-C 42-150	73-91	C42	150	SCMT120408	2.60
CT90115SA-C 42-80*	90-115	C42	80*	SCMT120408	3.30

◇刀片需单独订购。

◇订货示例：直柄粗镗刀1套 型号CT5674C-C 32-150

◇型号编制说明：
 CT 5674 C - C 32 - 150 - 镗孔深度
 柄径
 C型刀片
 镗孔范围
 CT-C系列镗刀

非标

非标镗刀

- 高效率：一把刀具可以在一次进给中完成多工序加工。
- 高刚性：由于是量身定制，刀具可以按加工要求设计成最高刚性结构。
- 超灵活：无论是超长超大还是特殊形状的刀具都能为您定制。

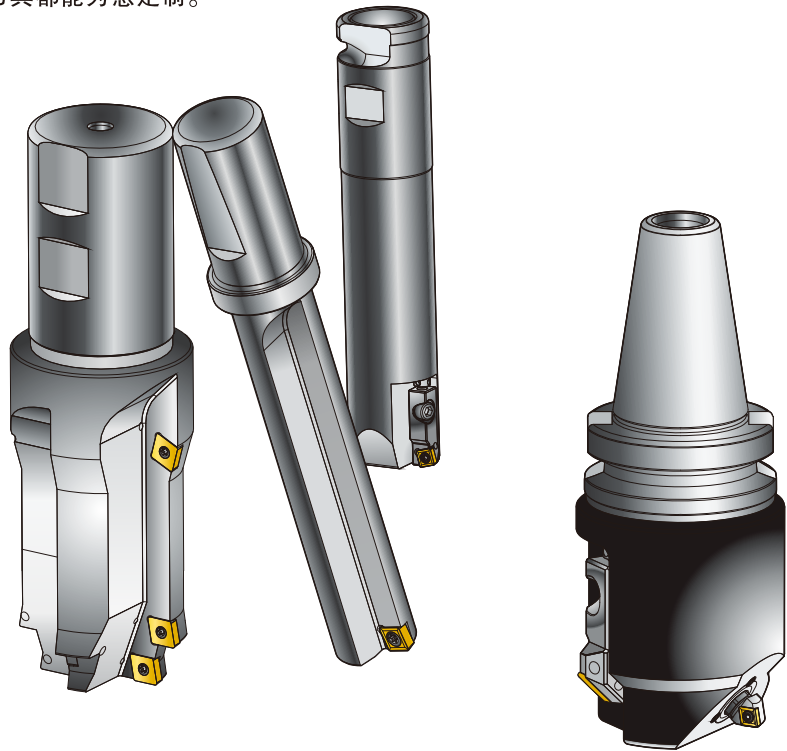

※定制非标刀具的一般步骤:

第一步：提供工件加工图纸，并详细注明需要加工位置的尺寸要求及工件的材质、硬度。

第二步：指定刀具柄部的型式，可以是BT等整体式主轴柄，也可以是削平柄或斜削平柄等直柄或其它任何形式的接口

第三步：尽可能详细的提供下述资料以便我们为您量身定制最符合您需求的刀具。

机床类型 _____

机床功率 _____

最大转速 _____

最大冷却液压力 _____

钻头旋转 工件旋转 垂直钻削 水平钻削

冷却方式 内冷 外冷

机床刚性 高 一般 差

◇如果您已经有设计好的非标刀具图纸，那么仅提供刀具图纸我们就可以为您加工。

◇尽可能详细的提供您需要定制刀具的相关资料，资料越详细，定制的刀具将越合用。

◇如果您还有其它要求请直接与我们的工程师沟通。

非标
镗刀夹

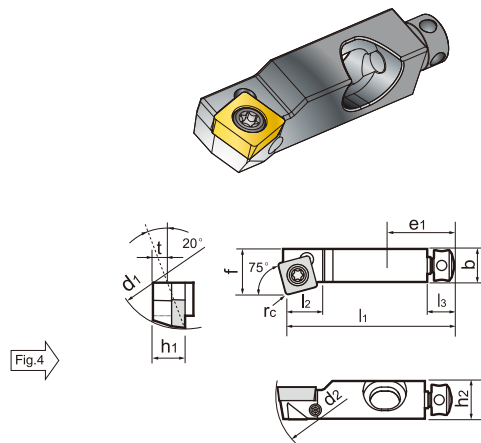
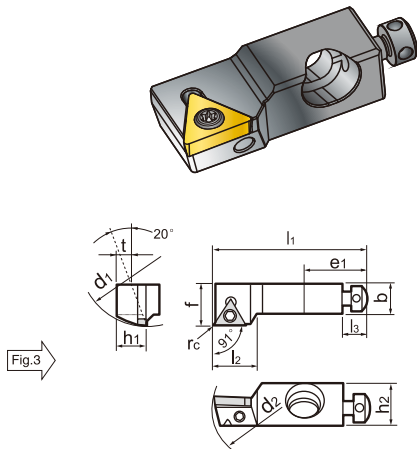
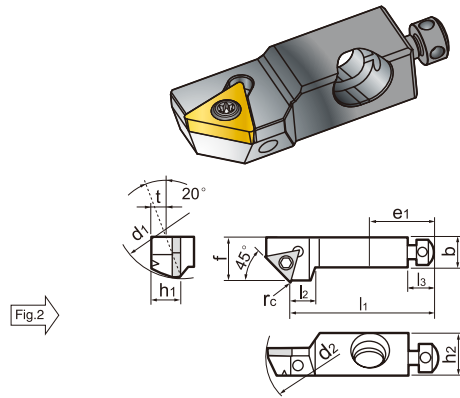
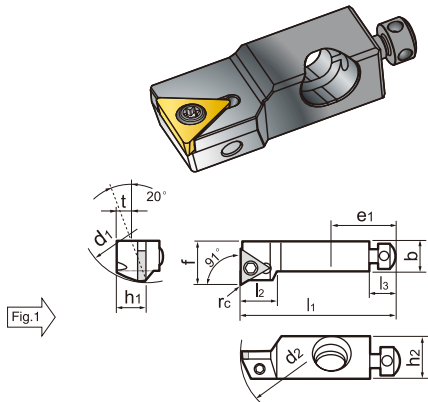





孔加工刀具
镗刀

型号	使用刀片	Fig.	最小加工直径		尺寸(mm)									
			φd1	φd2	r _c	f	l ₁	l ₂	h ₁	h ₂	b	e ₁	l ₃	t
SCFCR 08CA-0602	CCMT 060204	1	25	35	0.4	10	32	10	8	11.5	7.5	17	6	4.5
SCFCR 10CA-09T3	CCMT 09T308	1	40	55	0.8	14	50	12	10	14.5	10	20	8	5
SCFCR 12CA-1204	CCMT 120408	1	50	75	0.8	20	55	17	12	16.5	16	20	8	5
STFPR 08CA-0902	TPGT 090204	1	25	35	0.4	10	32	10	8	11.5	7.5	17	6	4.5
STFPR 10CA-1103	TPGT 110304	1	40	55	0.4	14	50	12	10	14.5	10	20	8	5
STFCR 12CA-16T3	TCMT 16T308	1	50	75	0.8	20	55	17	12	16.5	16	20	8	5
STSPR 08CA-0902	TPGT 090204	2	25	35	0.4	10	28	5.2	8	11.5	7.5	17	6	4.5
STSPR 10CA-1103	TPGT 110304	2	40	55	0.4	15	44	9	10	14.5	10	20	8	5
STSCR 12CA-16T3	TCMT 16T308	2	50	75	0.8	20	47	11	12	16.5	16	20	8	5
STGPL 08CA-0902	TPGT 090204	3	25	35	0.4	10	32	10.9	8	11.5	7.5	17	6	4.5
STGPL 10CA-1103	TPGT 110304	3	40	55	0.4	14	50	14	10	14.5	10	20	8	5
STGCL 12CA-16T3	TCMT 16T308	3	50	75	0.8	20	55	19	12	16.5	16	20	8	5
SSKCR 10CA-09T3	SCMT09T308	4	40	---	0.8	14	50	12	10	14.5	10	20	8	5
SSKCR 12CA-1204	SCMT120408	4	50	---	0.8	20	55	16	12	19.5	15	20	8	6
SSSCR 10CA-09T3	SCMT09T308	2	40	55	0.8	14	44	12	10	14.5	10	20	8	5
SSSCR 12CA-1204	SCMT120408	2	50	75	0.8	20	47	12	12	19.5	15	20	8	6

- 上表中d1是轴向安装时的最小加工直径，d2是径向安装时的最小加工直径；
- “Fig.1”中刀夹使用有方向性刀片时，镗刀夹的方向与刀片的方向相反。

非标

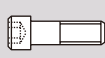
镗刀夹-配件

镗刀夹型号	刀片螺钉	轴向调节螺钉	径向调节螺钉	安装螺钉	扳手	扳手
						
SC□CR/L 08CA-0602	R 25050G	ASM34L	FM03006	BM04010	S1.5 S3	T8
ST□PR/L 08CA-0902	R 20050J					T6
SC□CR/L 10CA-09T3	R 40090G	ASM54	FM04010	BM06016	S2 S5	T15
ST□PR/L 10CA-1103	R 25060G					T8
SC□CR/L 12CA-1204	R 50110D		FM04014	BM06020		T20
ST□PR/L 12CA-16T3	R 40090G					T15

- 上表中“径向调节螺钉”为标准平端无头螺钉；
- 上表中“安装螺钉”为标准杯头螺钉。

孔加工镗刀刀片

C □ □ T □ □ □ □ □ □ (适合粗镗)

▲良好

△一般

	工件材质					P	中低硬度钢	▲				△	△	▲				
	工件材质					P	高硬度钢、合金钢	△				▲	▲	△				
	工件材质					M	不锈钢	▲										
	工件材质					K	铸铁					▲			▲	▲		
	工件材质					N	有色金属											
	工件材质					S	耐热合金											
	刀片基本尺寸					PVD涂层					CVD涂层				硬质合金			
	D	d	S	R	θ	PM8025	PM8012	PP8020	PP8030	KP1015	PC4115	PC4125	KC1015	KC1025	H101			
CCMT060204	6.35	2.8	2.38	0.4	7	○				●	●	●	○	●				
CCMT09T308	9.525	4.4	3.97	0.8	7	○				●	●	●	○	●				
CCMT120408	12.7	5.5	4.76	0.8	7	○				●	●	●	○	●				

●标准库存品 ○接受订货 ☆开发中, 近期供货

孔加工刀具
镗刀

TCMT □ □ □ □ □ □ (适合粗镗)

▲良好

△一般

	工件材质					P	中低硬度钢	▲				△	△	▲			
	工件材质					P	高硬度钢、合金钢	△				▲	▲	△			
	工件材质					M	不锈钢	▲									
	工件材质					K	铸铁					▲			▲	▲	
	工件材质					N	有色金属										
	工件材质					S	耐热合金										
	刀片基本尺寸					PVD涂层					CVD涂层				硬质合金		
	D	d	S	R		PM8025	PM8012	PP8020	PP8030	KP1015	PC4115	PC4125	KC1015	KC1025	H101		
TCMT090204	5.56	2.5	2.38	0.4		○				●	●	●	●	○			
TCMT110208	6.35	2.8	2.38	0.8		○				●	●	●	●	○			
TCMT16T308	9.525	4.4	3.97	0.8		○				●	●	●	●	○			

●标准库存品 ○接受订货 ☆开发中, 近期供货

孔加工镗刀刀片

SCMT □□□□□□ (适合粗镗)

▲良好 △一般

	工件材质	P 中低硬度钢	▲			△	△	▲						
		P 高硬度钢、合金钢	△				▲	▲	△					
		M 不锈钢	▲											
		K 铸铁								▲	▲			
		N 有色金属												
		S 耐热合金												
	刀片基本尺寸				PVD涂层					CVD涂层				硬合金
	D	d	S	R	PM8025	PM8012	PP8020	PP8030	KP1015	PC4115	PC4125	KC1015	KC1025	H101
SCMT09T308	9.525	4.4	3.97	0.8	○				●	●	●	○	●	
SCMT120408	12.7	5.5	4.76	0.8	○				●	●	●	○	●	

●标准库存品 ○接受订货 ☆开发中, 近期供货

W BGT /TBGT /TPGH /TPGT /TCGT □□□□□□ (适合精镗)

▲良好 △一般

	工件材质	P 中低硬度钢	▲	▲	▲		▲	▲			
		P 高硬度钢、合金钢	△	△	△		▲				
		M 不锈钢	△	△	△						
		K 铸铁	△	△	△		▲	△			
		N 有色金属						▲			
		S 耐热合金	△	△	△						
	刀片基本尺寸					PVD涂层				硬合金	硬合金
	D	d	S	R	θ	PM8025	PJ8120	WJ83220	PP8030	AX250	H101
WBGT060102L	3.97	2.3	1.59	0.2	5	●				●	○
TBGT060102L	3.97	2.3	1.59	0.2	5	●	●			●	●
TPGH080204L	3.97	2.3	1.59	0.2	5	●	●			●	●
TPGH090204L	5.56	3.0	2.38	0.4	11	●	●			●	●
TPGH110304L	6.35	3.3	3.18	0.4	11	●	●			●	●
TPGT090202L	5.56	3.0	2.38	0.2	11	●				●	○
TPGT090204L	5.56	3.0	2.38	0.4	11	●				●	○
TPGT110302L	6.35	3.3	3.18	0.2	11	●				●	○
TPGT110304L	6.35	3.3	3.18	0.4	11	●				●	○
TCGT080202L	3.97	2.3	1.59	0.2	5		●	●			
TCGT080204L	3.97	2.3	1.59	0.2	5		●	●			
TCGT110202L	4.76	2.3	2.38	0.2	11		●	●			
TCGT110204L	4.76	2.3	2.38	0.4	11		●	●			

●标准库存品 ○接受订货 ☆开发中, 近期供货

◎ 孔加工刀具 镗刀